

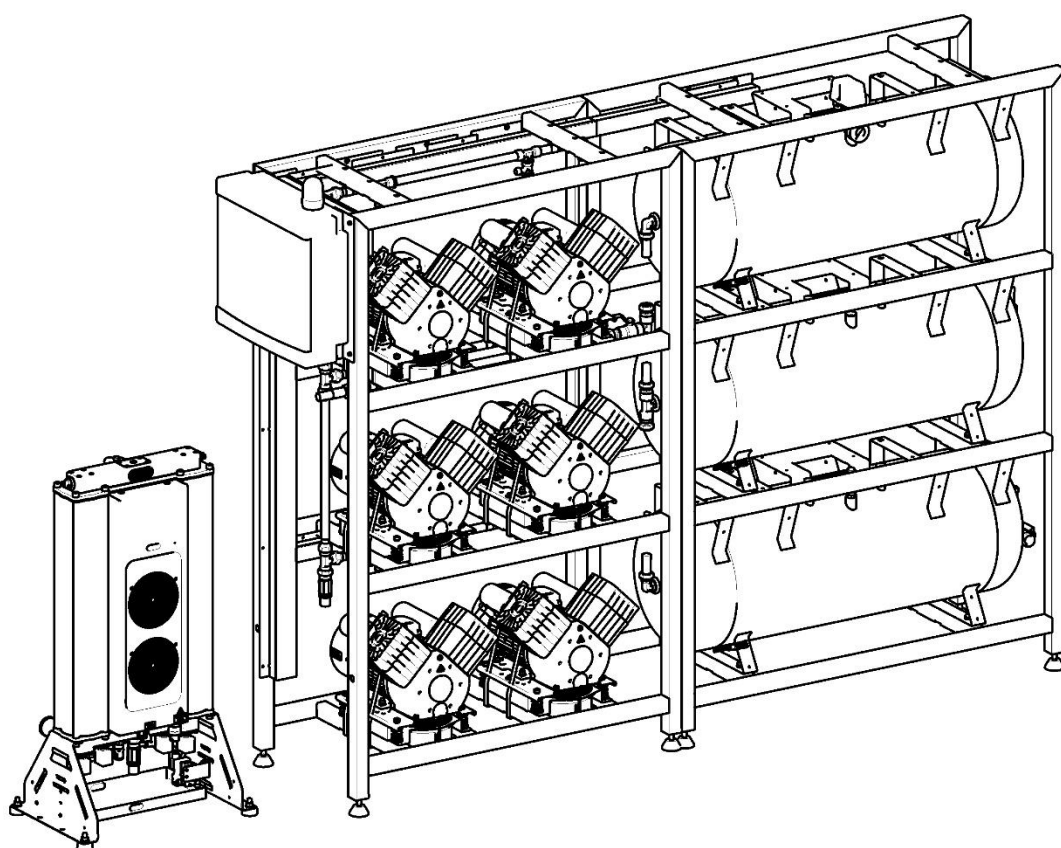

# DK50 6X2VT/M

EN USER MANUAL



CE



**COMPRESSOR**

**DK50 6x2VT/M**



**EKOM spol. s r. o.**  
Priemyselná 5031/18  
SK-921 01 Piešťany  
Slovak Republic  
tel.: +421 33 7967255  
fax: +421 33 7967223

[www.ekom.sk](http://www.ekom.sk)  
email: [ekom@ekom.sk](mailto:ekom@ekom.sk)

**DATE OF LAST REVISION**

10/2024



NP-DK50-Nx2VTM-AD-EN-  
12\_10-2024  
112000481-0001

**CONTENTS**

<b>IMPORTANT INFORMATION .....</b>	<b>5</b>
1. CONFORMITY WITH THE REQUIREMENTS OF THE EUROPEAN UNION.....	5
2. INTENDED USE.....	5
3. CONTRAINDICATIONS AND SIDE-EFFECTS .....	5
4. SYMBOLS.....	5
5. WARNINGS .....	6
6. STORAGE AND TRANSPORT CONDITIONS .....	8
<b>PRODUCT DESCRIPTION .....</b>	<b>9</b>
7. VARIANTS .....	9
8. ACCESSORIES .....	10
9. PRODUCT FUNCTION .....	11
<b>TECHNICAL DATA.....</b>	<b>15</b>
<b>INSTALLATION .....</b>	<b>23</b>
10. INSTALLATION CONDITIONS.....	23
11. COMPRESSOR ASSEMBLY .....	24
12. PNEUMATIC CONNECTION .....	27
13. ELECTRICAL CONNECTION .....	30
14. COMMISSIONING .....	32
15. PNEUMATIC DIAGRAMS .....	33
<b>OPERATION .....</b>	<b>35</b>
16. SWITCHING THE COMPRESSOR .....	36
17. SWITCHING OFF THE COMPRESSOR .....	39
<b>PRODUCT MAINTENANCE .....</b>	<b>40</b>
18. PRODUCT MAINTENANCE.....	40
<b>TROUBLESHOOTING .....</b>	<b>54</b>
19. REPAIR SERVICE .....	56
20. LONG-TERM SHUTDOWN .....	56
21. DISPOSAL OF DEVICE .....	56

**IMPORTANT INFORMATION**

**1. CONFORMITY WITH THE REQUIREMENTS OF THE EUROPEAN UNION**

This product conforms to the requirements of the Regulation (EU) on medical devices (MDR

2017/745) and is safe for the intended use if all safety instructions are followed.

**2. INTENDED USE**

The compressor is used as a source of clean, oil-free compressed air to power active medical devices where the parameters and properties of the compressed air are suitable for the specific application.



**Compressed air supplied by the compressor is unsuitable for use with artificial lung ventilation devices without further filtration**

Any other use of the product beyond its intended use is considered an incorrect use. The manufacturer is not liable for any damages or injuries resulting from the incorrect use.

**3. CONTRAINDICATIONS AND SIDE-EFFECTS**

There are no contraindications or side-effects known.

**4. SYMBOLS**

The following symbols and marks are used in the User manual, on the device and its packaging:



General warning



Warning - risk of electric shock



Warning - compressor is controlled automatically



Warning - hot surface



General caution



Refer to instruction manual



CE – marking













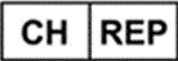



Medical device



Serial number



Article number

	Unique Device Identifier
	Swiss Authorised Representative
	Swiss Importer
	Protecting earthing
	Terminal for ground connection
	Alternating current
	Compressed air inlet - dryer
	Compressed air outlet - dryer
	Package handling label – fragile
	Package handling label – this side up
	Package handling label – keep dry
	Package handling label – temperature limits
	Package handling label – limited stacking
	Package label – recyclable material
	Manufacturer

## 5. WARNINGS

The product is designed and manufactured to be safe for the user and the surrounding environment when used in the defined manner. Keep the following warnings in mind.

### 5.1. General warnings

**READ THE USER MANUAL CAREFULLY BEFORE USING THE DEVICE AND KEEP IT FOR FUTURE USE!**

- The user manual supports the correct installation, operation and

maintenance of the product. Careful review of this manual will provide the information necessary for the correct operation of the product for its intended use.

- Original packaging should be retained for the return of the device. Only the original packaging ensures protection of the device during transport. If it is necessary to return the product during the warranty period, the manufacturer

is not liable for damages caused by improper packaging.

- This warranty does not cover damages originating from the use of accessories other than those specified or recommended by the manufacturer.
- The manufacturer only guarantees the safety, reliability and function of the device if:
  - installation, new settings, changes, expansion, and repairs are performed by the manufacturer or an organisation authorised by the manufacturer.
  - the product is used pursuant to the user manual.
- The user manual corresponds to the configuration of the product and its compliance with the applicable safety and technical standards at the time of printing. The manufacturer reserves all rights for the protection of its configuration, methods and names.
- Translation of the user manual is performed in accordance with the best available knowledge. The Slovak version is to be used in the event of any uncertainties.
- This user manual is the original instructions. Translation is performed in accordance with the best available knowledge.

### 5.2. General safety warnings

The manufacturer designed and manufactured the product to minimise all risks when used correctly for the intended use. The manufacturer considers it its obligation to lay down the following general safety precautions.

- Use and operation of the product must comply with all laws and local regulations valid in the place of use. The operator and user are responsible for following all the appropriate regulations in the interests of performing work safely.
- Only the use of original parts guarantees the safety of operating personnel and the flawless operation

of the product itself. Only the accessories and parts mentioned in the technical documentation or expressly approved by the manufacturer should be used.

- The operator must ensure that the device is functioning correctly and safely before every use.
- The user must be familiar with the operation of the device.
- Do not use the product in environments with a risk of explosion.
- The user must inform the supplier immediately if any problem directly related to the operation of the device occurs.
- Any serious incident that has occurred in relation to the device should be reported to the manufacturer and the competent authority of the Member State in which the user and / or patient is established.

### 5.3. Safety warnings on protection from electric current

- The device must only be connected to a properly installed, earthed socket.
- Before the product is plugged in, ensure that the mains voltage and frequency stated on the product are in compliance with the values of the mains.
- Prior to putting the device into operation check for any damage to the connected pneumatic lines and electrical wiring. Replace damaged pneumatic lines and electrical wirings immediately.
- Immediately disconnect the product from the mains (remove power cord from the socket) in hazardous situations or in the case of a technical malfunction.
- During all repairs and maintenance, ensure that:
  - the mains plug is removed from the power socket
  - pressure is vented from the air tank and pipes

- The product shall only be installed by a qualified technician.

## 6. STORAGE AND TRANSPORT CONDITIONS

The compressor is shipped from the manufacturer in transport packaging. This protects the product from damage during transport.



**Potential for damage to pneumatic components.**

**The compressor must be transported only when all air has been vented. Before moving or transporting the compressor, release all the air pressure from the tank and pressure hoses, from dryer chambers and drain condensate from the tank and from the condensate separator on the dryer.**



**Keep the original factory packaging in case the device needs to be returned. Use the original factory packaging during transport as it provides optimum protection for the product. . If it is necessary to return the product during the warranty period, the manufacturer is not liable for damages caused by improper packaging.**



**The compressor is shipped in a vertical position and must be secured using transport straps.**



Protect the compressor from humid and dirty environments and extreme temperatures during transport and storage. Do not store near any volatile chemical substances.



If not, please dispose of the original packaging material in an environmentally-friendly way. The packaging cardboard can be recycled with old paper.



Storing or shipping the equipment in any conditions other than those specified below is prohibited.

### 6.1. Ambient conditions

Products may only be stored and transported in vehicles that are free of any traces of volatile chemicals under the following climactic conditions:

<b>Temperature</b>	–25°C to +55°C, 24 h at up to +70°C
<b>Relative humidity</b>	max. 90% (non-condensing)



**PRODUCT DESCRIPTION**

**7. VARIANTS**

The compressor is manufactured according to its intended application in the following variants:

<b>DK50 6x2VT/M</b>	Composed of modules:
	1 compressor module - 6x2V air pumps
	2 adsorption dryer
	3 air tank module– 3x110 l

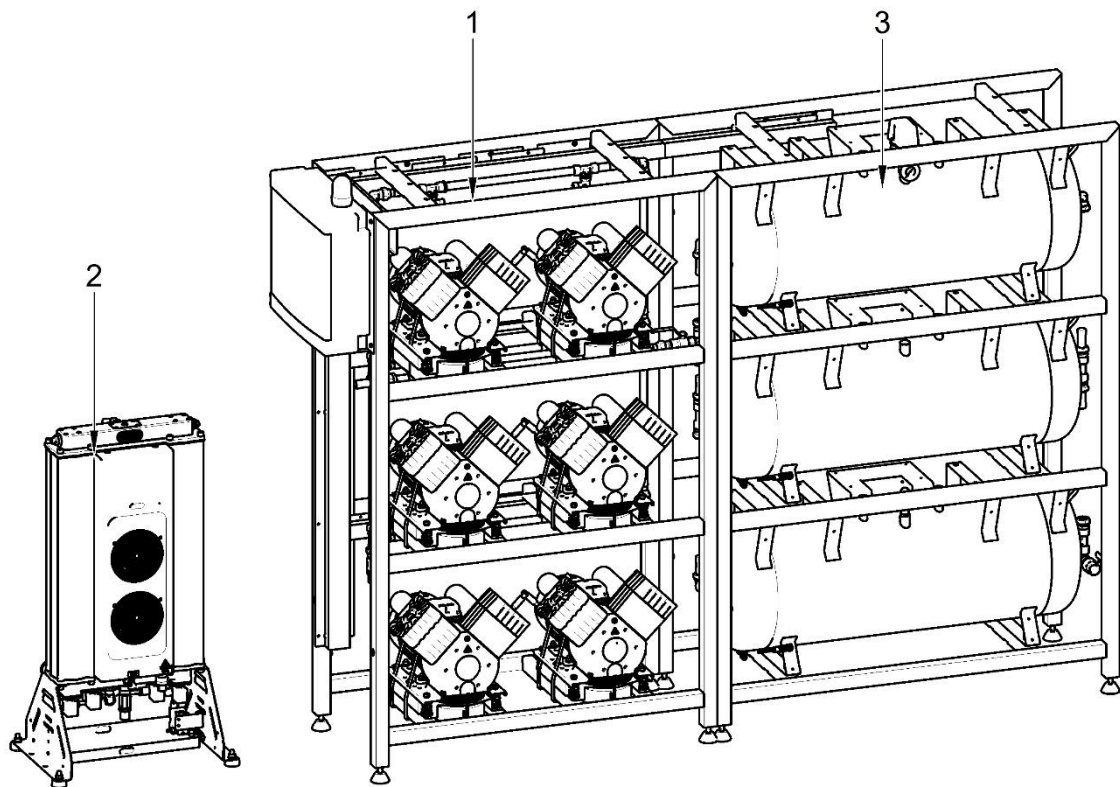

**DK 50 6x2VT/M**

## 8. ACCESSORIES

Accessories that are not included in the standard order must be ordered separately.

### Set of compressed air outlet filters

The compressor may be equipped with a set of filters if specified. The filter set may be

equipped with an air pressure regulator.



**Where a different level of air filtration is required, this requirement must be agreed upon with the supplier and specified in the order.**

Type	Use	Level of filtration (µm)	Bypass function *	Article number
FS 40F		1		604014119-000
FS 40M	DK50 6x2VT/M	1+0.1	no	604014119-004
FS 40S		1+0.01		604014119-024
FS 40AH		1+AC+HC(0.01)		604014119-005

\*) These FS do not contain a filter bypass, which will ensure a continuous flow of air

when replacing the filter element. Such a set must be ordered separately.

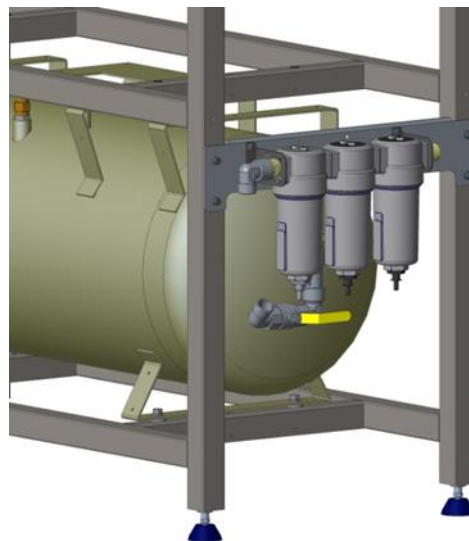

Set of filters

### Filter set regulator assembly

The compressor may be equipped with a pressure regulator of the compressed air outlet if specified. The regulator must be selected according to the application to the filter set, or separately. The regulator shall ensure constant pressure at the outlet.

Type	Use	Article number
Regulator complete	DK50 6x2VT/M	604014125-000

### Filter set brackets



**A suitable bracket must be ordered for every filter set.**

Type	Use	Article number
Compressor-mounted bracket	DK50 6x2VT/M	603014137-000
Wall-mounted bracket		603014120-000

**9. PRODUCT FUNCTION**

**9.1. Compressor with adsorption dryer**

The compressor air pumps (1) draw in air through the inlet filter (8) and compress it through a non-return valve and into a manifold, from which it is routed to the adsorption dryer (3) through a connecting hose. From the inlet to the dryer module, the air is first cooled in the integrated cooler (17) and then moves through the condensate

separator (29), entering the active chamber with adsorbent (19), where the air is then dried. A portion of the dry air is fed into the second, regeneration chamber, where this air is used to remove moisture from the adsorbent, after which it is released with the accumulated condensate through the silencer (27). Chamber operation (desiccant regeneration) is cyclically switched. Dry and filtered air then passes through the non-return valve into the air tank (2).

**Description for figures 1-3:**

- |                                 |                                 |
|---------------------------------|---------------------------------|
| 1. Air pump                     | 18. Inlet valve module          |
| 2. Air tank                     | 19. Dryer chamber               |
| 3. Adsorption dryer             | 20. -                           |
| 4. Electrical box / switchboard | 21. Outlet module               |
| 5. Frame                        | 22. Regeneration solenoid valve |
| 6. Pressure switch              | 23. Regeneration solenoid valve |
| 7. Drain valve                  | 24. Inlet solenoid valve        |
| 8. Magnetic holder              | 25. Inlet solenoid valve        |
| 9. Condensate collection vessel | 26. Relief valve                |
| 10. Pressure gauge              | 27. Noise silencer              |
| 11. Three-pole circuit breaker  | 28. Compressed air inlet        |
| 12. Single-pole circuit breaker | 29. Condensate separator        |
| 13. LOGO control electronics    | 30. Pressure gauge              |
| 14. Indicator                   | 31. Automatic condensate drain  |
| 15. Contactor                   | 32. Dryer pan                   |
| 16. Thermal overcurrent relays  | 33. Air outlet                  |
| 17. Cooler module               |                                 |

Fig. 1: Compressor with adsorption dryer

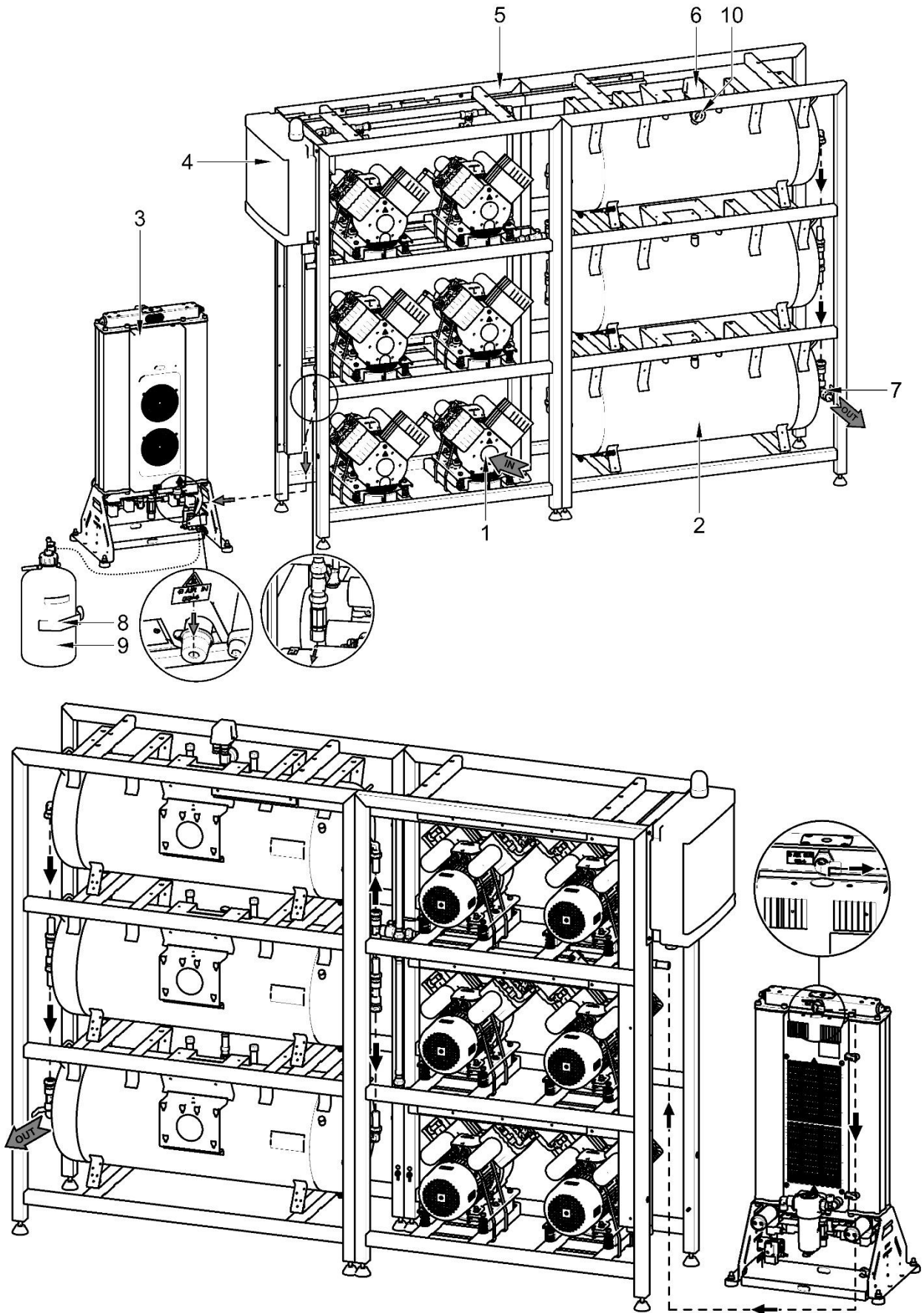

Fig. 2: Adsorption dryer

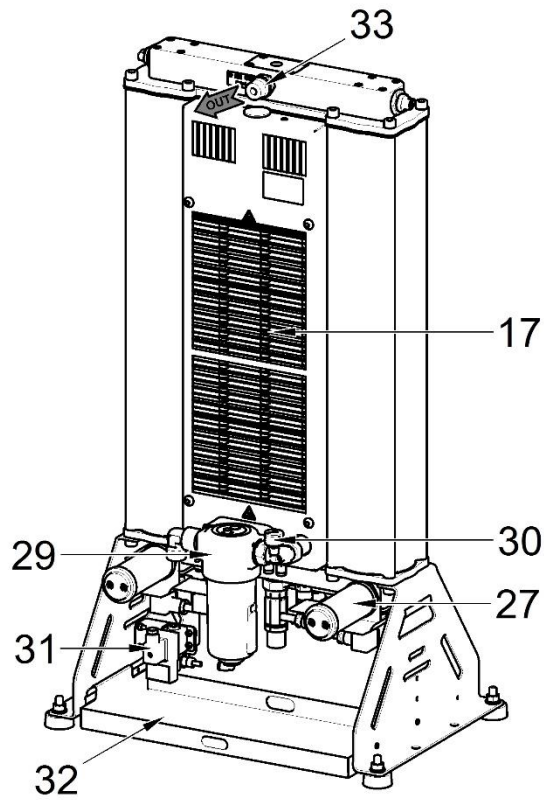
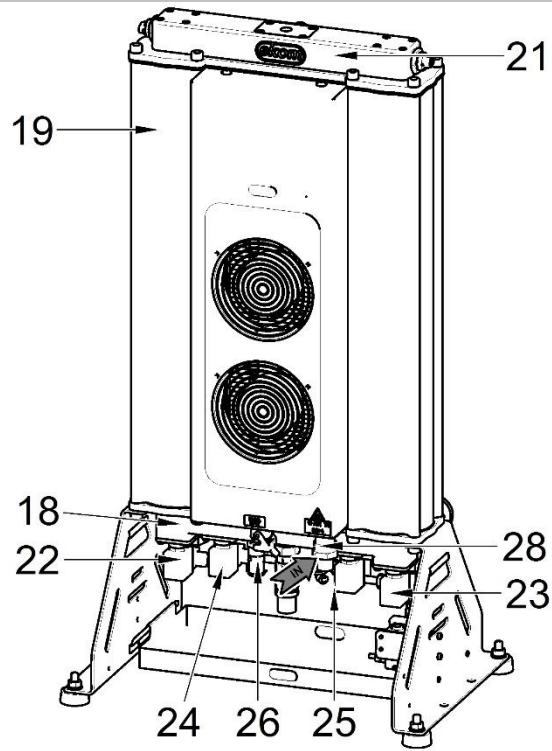
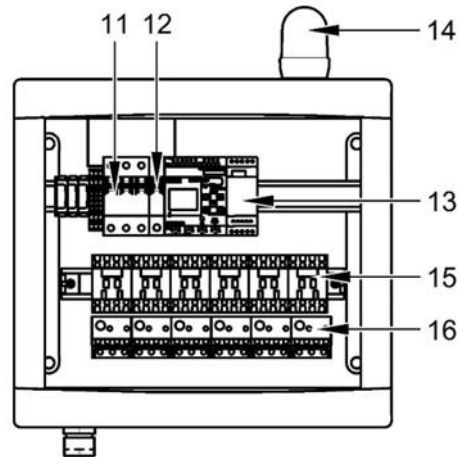

Fig. 3: Electrical box / switchboard



The range of the pressure switch on the configured assemblies may only be adjusted after prior consultation with the manufacturer.



Adjusting the pressure setting of the safety valve is expressly prohibited.

The pressure relief valve automatically begins to vent air from the system if the pressure in the compressed air circuit exceeds its pre-set value. The pressure relief valve then closes as the pressure drops.



Pressure in the compressed air circuit can only increase because of an increase in flow resistance in the compressed air lines or as a result of a dryer malfunction (e.g. solenoid valve malfunction, an increase in flow resistance through the drying media, etc.), and therefore the repeated opening of the relief valve requires a dryer function check and repairs if necessary.



Consultation with the manufacturer is required before any adjustment is made to the relief valve!

The outlet openings on the relief valve must not be blocked and the flow of compressed air through them may not be restricted.

**TECHNICAL DATA**

Compressors are designed for operation in dry, ventilated and dust-free indoor rooms under the following climactic conditions:

<b>Temperature</b>	+5°C to +40°C
<b>Relative humidity</b>	max. 70%

<b>Working pressure 6 – 8 bar</b>		<b>DK50 6x2VT/M</b>
Rated voltage	V, Hz	3x400, 50
Frequency <sup>a)</sup>		
Capacity at 6 bar (FAD) -20°C	l/min	710
Working pressure <sup>b)</sup>	bar	6.0 – 8.0
Rated current	A	22
Main circuit protection device rating	A	50
Main electrical feeder	mm <sup>2</sup>	10
Enclosure		IP10
Motor power	kW	1.2
Air tank volume	l	330
Air quality - filtration	µm	-
Maximum operating pressure of safety valve	bar	12.0
Noise level at 5 bar (L <sub>pA</sub> )	dB	≤73
Operating mode	%	S1-100
PDP drying performance at 7 bar <sup>d)</sup>	°C	≤ -20
Time to fill air tank from 0 to 7 bar	s	226
Net weight compressor <sup>c)</sup>	kg	413
Dimensions compressor (net) w x l x h	mm	2340x510x1730
Net weight dryer <sup>c)</sup>	kg	46
Dimensions dryer (net) w x l x h	mm	530x350x965
Required cooling air changes in space	m <sup>3</sup> /h	1500
Electrical class		Class I.

- <sup>a)</sup> Specify the compressor version when ordering
- <sup>b)</sup> Consult any other range of pressure with the supplier
- <sup>c)</sup> Weight is indicative and only applies to the product without accessories
- <sup>d)</sup> Applies to ambient temperatures of <30°C PDP – pressure dew point

Dependence of compressor output on working pressure

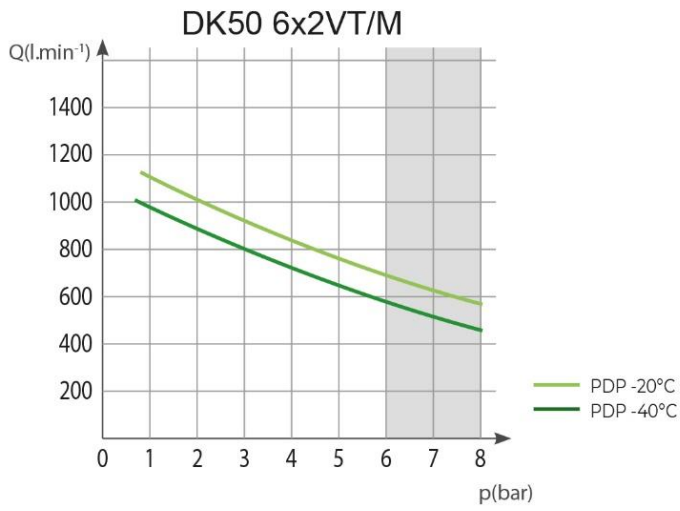



Working pressure 6 – 8 bar		DK50 6x2VT/M
Rated voltage Frequency <sup>a)</sup>	V, Hz	3x400, 50
Output at 6 bar (FAD) at PDP-40°C	l/min	680
Working pressure <sup>b)</sup>	bar	6.0 – 8.0
Rated current	A	22
Main circuit protection device rating	A	50
Main electrical feeder	mm <sup>2</sup>	10
Enclosure		IP10
Motor output	kW	1.2
Air tank capacity	l	330
Air quality – filtration	µm	-
Maximum operating pressure of safety valve	bar	12.0
Noise at 5 bar (L <sub>pA</sub> )	dB	≤73
Operating mode	%	S1-100
PDP drying performance at 7 bar <sup>d)</sup>	°C	≤ -40
Time to fill air tank from 0 to 7 bar	s	226
Net weight compressor <sup>c)</sup>	kg	413
Dimensions compressor (net) w x l x h	mm	2340x510x1730
Net weight dryer <sup>c)</sup>	kg	46
Dimensions dryer (net) w x l x h	mm	530x350x965
Required cooling air changes in space	m <sup>3</sup> /h	1500
Electrical class		Class I.

- a) Specify the compressor version when ordering
- b) Consult any other range of pressure with the supplier
- c) Weight is indicative and only applies to the product without accessories
- d) Applies to ambient temperatures of <30°C PDP – pressure dew point

Dependence of compressor output on working pressure

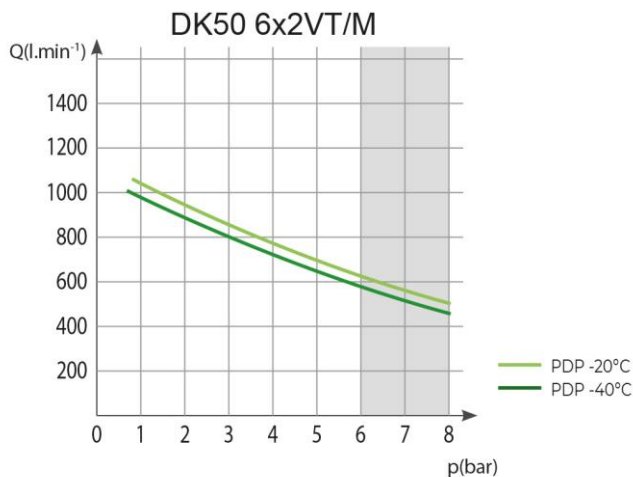

<b>Working pressure 8 – 10 bar</b>		<b>DK50 6x2VT/M</b>
Rated voltage	V, Hz	3x400, 50
Frequency <sup>a)</sup>		
Output at 6 bar (FAD) at PDP-20°C	l/min	550
Working pressure <sup>b)</sup>	bar	8.0 – 10.0
Rated current	A	25
Main circuit protection device rating	A	50
Main electrical feeder	mm <sup>2</sup>	10
Enclosure		IP10
Motor output	kW	1.2
Air tank capacity	l	330
Air quality – filtration	µm	-
Maximum operating pressure of safety valve	bar	12.0
Noise at 5 bar (L <sub>pA</sub> )	dB	≤73
Operating mode	%	S1-100
PDP drying performance at 7 bar <sup>d)</sup>	°C	≤ -20
Time to fill air tank from 0 to 7 bar	s	226
Net weight compressor <sup>c)</sup>	kg	413
Dimensions compressor (net) w x l x h	mm	2340x510x1730
Net weight dryer <sup>c)</sup>	kg	46
Dimensions dryer (net) w x l x h	mm	530x350x965
Required cooling air changes in space	m <sup>3</sup> /h	1500
Electrical class		Class I.

- a) Specify the compressor version when ordering
- b) Consult any other range of pressure with the supplier
- c) Weight is indicative and only applies to the product without accessories
- d) Applies to ambient temperatures of <30°C PDP – pressure dew point

#### Dependence of compressor output on working pressure

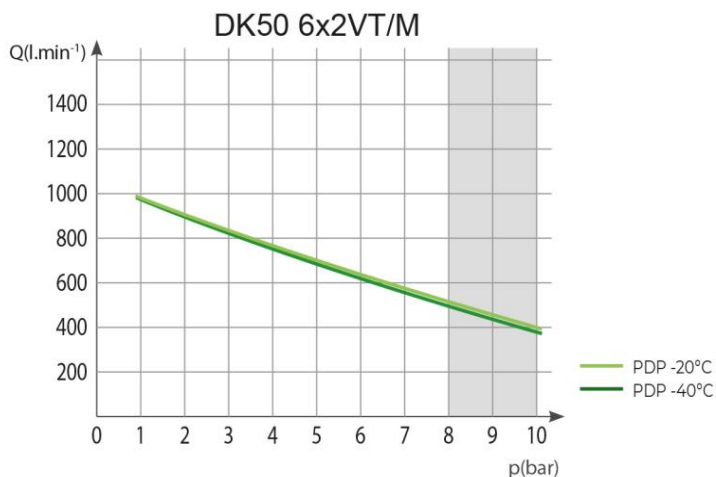

Working pressure 8 – 10 bar		DK50 6x2VT/M
Rated voltage Frequency <sup>a)</sup>	V, Hz	3x400, 50
Output at 8 bar (FAD) at PDP-40°C	l/min	520
Working pressure <sup>b)</sup>	bar	8.0 – 10.0
Rated current	A	25
Main circuit protection device rating	A	50
Main electrical feeder	mm <sup>2</sup>	10
Enclosure		IP10
Motor output	kW	1.2
Air tank capacity	l	330
Air quality – filtration	µm	-
Maximum operating pressure of safety valve	bar	12.0
Noise at 5 bar (L <sub>pA</sub> )	dB	≤73
Operating mode	%	S1-100
PDP drying performance at 7 bar <sup>d)</sup>	°C	≤ -40
Time to fill air tank from 0 to 7 bar	s	226
Net weight compressor <sup>c)</sup>	kg	413
Dimensions compressor (net) w x l x h	mm	2340x510x1730
Net weight dryer <sup>c)</sup>	kg	46
Dimensions dryer (net) w x l x h	mm	530x350x965
Required cooling air changes in space	m <sup>3</sup> /h	1500
Electrical class		Class I.

- <sup>a)</sup> Specify the compressor version when ordering
- <sup>b)</sup> Consult any other range of pressure with the supplier
- <sup>c)</sup> Weight is indicative and only applies to the product without accessories
- <sup>d)</sup> Applies to ambient temperatures of <30°C PDP – pressure dew point

Dependence of compressor output on working pressure

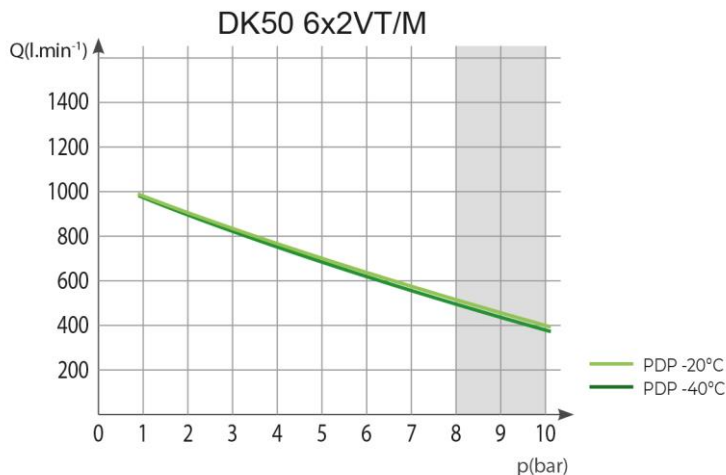

**FAD correction of capacity for altitude**

Capacity given in the form of FAD („Free Air Delivery“) applies to the following conditions:

Altitude	0 m.n.m.	Temperature	20°C
Atmospheric pressure	101325 Pa	Relative humidity	0%

To calculate FAD compressor capacity in dependence on altitude, it is necessary to apply correction factor according to the following table:

Altitude [m.n.m.]	0 -1500	1501 - 2500	2501 - 3500	3501 - 4500
<b>FAD correction factor</b>	1	0.80	0.71	0.60

**Electromagnetic compatibility declaration**

Medical equipment needs special precautions regarding electromagnetic compatibility

(EMC) and needs to be installed and put into service according to the EMC information provided below.

Guidance and manufacturer's declaration - electromagnetic emissions		
Pursuant to IEC 60601-1-2:2014/AMD1:2020 - Medical electrical equipment - Part 1-2: General requirements for basic safety and essential performance - Collateral Standard: Electromagnetic disturbances		
The equipment is intended for use in the electromagnetic environment specified below. The customer or the user of the equipment should assure that it is used in such an environment.		
Emissions test	Compliance	Electromagnetic environment - guidance
RF emissions CISPR 11	Group 1	The equipment uses RF energy only for its internal functions. Therefore, the RF emissions are very low and are not likely to cause any interference in nearby electronic equipment.
RF emissions CISPR 11	Class B	The equipment is suitable for use in all establishments, including domestic establishments and those directly connected to the public low voltage power supply network that supplies buildings used for domestic purposes.
Harmonic emissions IEC 61000-3-2	Class A	
Voltage fluctuations/ flicker emissions IEC 61000-3-3	The equipment is not likely to cause any flicker, as the current flow is approx. constant after the start up.	

<b>Guidance and manufacturer's declaration - electromagnetic immunity</b>			
Pursuant to IEC 60601-1-2:2014/AMD1:2020 - Medical electrical equipment - Part 1-2: General requirements for basic safety and essential performance - Collateral Standard: Electromagnetic disturbances			
The equipment is intended for use in the electromagnetic environment specified below. The customer or the user of the equipment should assure that it is used in such an environment.			
<b>Immunity test</b>	<b>IEC 60601-1-2 test level</b>	<b>Compliance level</b>	<b>Electromagnetic environment - guidance</b>
Electrostatic discharge (ESD) IEC 61000-4-2	±8 kV contact ±15 kV air	±8 kV contact ±15 kV air	Floors should be wood, concrete or ceramic tile. If floors are covered with synthetic material, the relative humidity should be at least 30%.
Electrical fast transient/burst IEC 61000-4-4	±2 kV for power supply lines ±1 kV for input/output lines	±2 kV 100 kHz repetition frequency Applied to mains connection	Mains power quality should be that of a typical commercial or hospital environment.
Surge IEC 61000-4-5	±1 kV differential mode ±2 kV common mode	±1 kV L-N ±2 kV L-PE; N-PE Applied to mains connection	Mains power quality should be that of a typical commercial or hospital environment.
Voltage dips, short interruption, and voltage variations on power supply input lines IEC 60601-4-11	$U_T=0\%$ , 0,5 cycle (at 0, 45, 90, 135, 180, 225, 270 and 315°) $U_T=0\%$ , 1 cycle $U_T=70\%$ 25/30 cycles (at 0°) $U_T=0\%$ , 250/300 cycles	$U_T=>95\%$ , 0,5 cycle (at 0, 45, 90, 135, 180, 225, 270 and 315°) $U_T=>95\%$ , 1 cycle $U_T=70\%$ (30% dipp $U_T$ ), 25(50Hz)/30(60Hz) cycles (at 0°) $U_T=>95\%$ , 250(50Hz)/300(60Hz) cycle	Mains power quality should be that of a typical commercial or hospital environment. The device stops and restarts automatically at each dip. In this case does not occur unacceptable pressure drop.
Power frequency (50/60 Hz) IEC 61000-4-8	N/A	N/A	The equipment does not contain magnetically sensitive components or circuits.
Radiated fields in close proximity per IEC 61000-4-39	N/A	N/A	The equipment does not contain magnetically sensitive components or circuits.
NOTE: $U_T$ is the A.C. mains voltage prior to application of the test level.			

Guidance and manufacturer's declaration - electromagnetic immunity			
Pursuant to IEC 60601-1-2:2014/AMD1:2020 - Medical electrical equipment - Part 1-2: General requirements for basic safety and essential performance - Collateral Standard: Electromagnetic disturbances			
The equipment is intended for use in the electromagnetic environment specified below. The customer or the user of the equipment should assure that it is used in such an environment.			
Immunity test	IEC 60601-1-2 test level	Compliance level	Electromagnetic environment - guidance
Conducted RF IEC 61000-4-6	3 Vrms 150 kHz to 80MHz	3 Vrms	<p>Portable and mobile RF communications equipment should be used no closer to any part of the equipment, including cables, than the recommended separation distance calculated from the equation applicable to the frequency of the transmitter.</p> <p><b>Recommended separation distance</b></p> $d=1,2\sqrt{P}$ $d=1,2\sqrt{P}, 80 \text{ MHz to } 800 \text{ MHz}$ $d=2,3\sqrt{P}, 800 \text{ MHz to } 2,7 \text{ GHz}$ <p>where P is the maximum output power rating of the transmitter in watts (W) according to the transmitter manufacturer and d is the recommended separation distance in metres (m).</p> <p>Field strengths from fixed RF transmitters, as determined by an electromagnetic site survey <sup>a</sup>, should be less than the compliance level in each frequency range <sup>b</sup>. Interference may occur in the vicinity of equipment marked with the following symbol:</p> 
Radiated RF IEC 61000-4-3	3 V/m 80 MHz to 2,7 GHz	3 V/m	
Proximity fields from RF wireless communications equipment IEC 61000-4-3	9 to 28 V/m 15 specific frequencies (380 to 5800 MHz)	9 to 28 V/m 15 specific frequencies (380 to 5800 MHz)	
NOTE 1 At 80 MHz and 800 MHz, the higher frequency range applies.			
NOTE 2 These guidelines may not apply in all situations. Electromagnetic propagation is affected by absorption and reflection from structures, objects and people.			
<sup>a</sup> Field strengths from fixed transmitters, such as base stations for radio (cellular/cordless) telephones and land mobile radios, amateur radio, AM and FM radio broadcast and TV broadcast cannot be predicted theoretically with accuracy. To assess the electromagnetic environment due to fixed RF transmitters, an electromagnetic site survey should be considered. If the measured field strength in the location in which the equipment is used exceeds the applicable RF compliance level above, the equipment should be observed to verify normal operation. If abnormal performance is observed, additional measures may be necessary, such as re-orienting or relocating the equipment.			
<sup>b</sup> Over the frequency range 150 kHz to 80 kHz, field strengths should be less than 3 V/m.			

**INSTALLATION**



**Risk of incorrect installation.**

Only a qualified technician may install the compressor and place it into operation for the first time. Their duty is to train operating personnel on the use and maintenance of the equipment. An entry is made in the equipment installation record to certify installation and operator training. (See warranty card)

**10. INSTALLATION CONDITIONS**

- The compressor may only be installed and operating in dry, well-ventilated and clean environments under the conditions specified in the Technical Data chapter.



**Risk of damage to the device.**

The equipment may not be operated outdoors or in otherwise wet or damp environments.



**Risk of explosion.**

Do not use the equipment in the presence of explosive gases, dust or combustible liquids.

- The compressor must be installed so that it is accessible at all times for operating and maintenance. Please ensure that the nameplate on the device is readily accessible.
- The compressor must stand on a flat, sufficiently stable base (be aware of the weight of the compressor, see the Technical Data chapter).
- The compressor on the operator's side must be at least 70 cm from the wall to allow air flow for cooling purposes and to ensure the safety of the operator and maintenance personnel.
- Approximately 70% of the electrical energy used by the compressor aggregates is converted to heat, and therefore the rooms in which the

compressor is installed must have additional ventilation to provide sufficient air exchange for cooling purposes (see the Technical Data chapter).



**Burn or fire hazard! Caution! Hot surface!**

Portions of the compressor, dryer and connecting hoses between the dryer and compressor may be hot and reach hazardous temperatures during compressor operation that may harm materials or operating staff.



**High temperature hazard**

Placing air flow impediments upstream or downstream of the cooler is prohibited. The temperature of internal and external parts of the equipment may rise to hazardous levels.



Ensure the power cords and air hoses are not damaged. The power cord must not show signs of stress and must be kept without tension (placing any objects on it is prohibited), and subjecting the cord to external heat in any form is prohibited.



You may notice a “new product” odour when you first place the product into service (for a short period of time). This odour is temporary and does not impede the normal use of the product. Ensure the space is properly ventilated after installation.

**Fig. 4: Equipment installation**

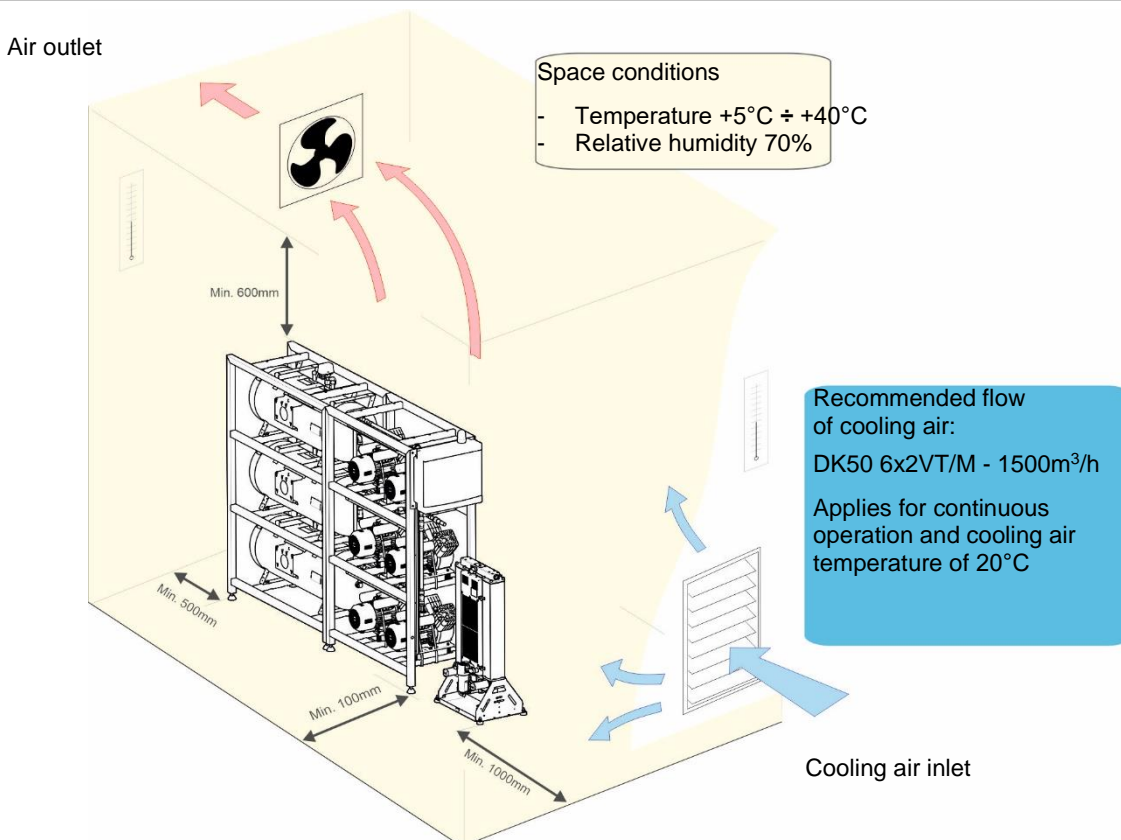

## 11. COMPRESSOR ASSEMBLY

### 11.1. Handling and releasing the compressor

- Unpack the compressor (compressor modules, dryer and air tank) from the packaging and remove the transport anchors from the pallet. All modules are secured to pallets.
- Use a fork lift or similar hoisting equipment to handle and position the product.
- Position the compressor module at the site of installation. (Fig. 5)



Fig. 5: Handling the compressor module

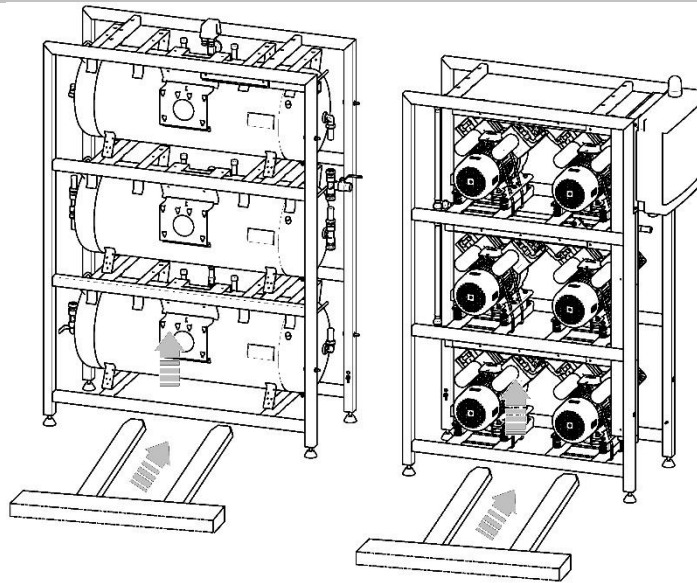

Fig. 6: Levelling the compressor

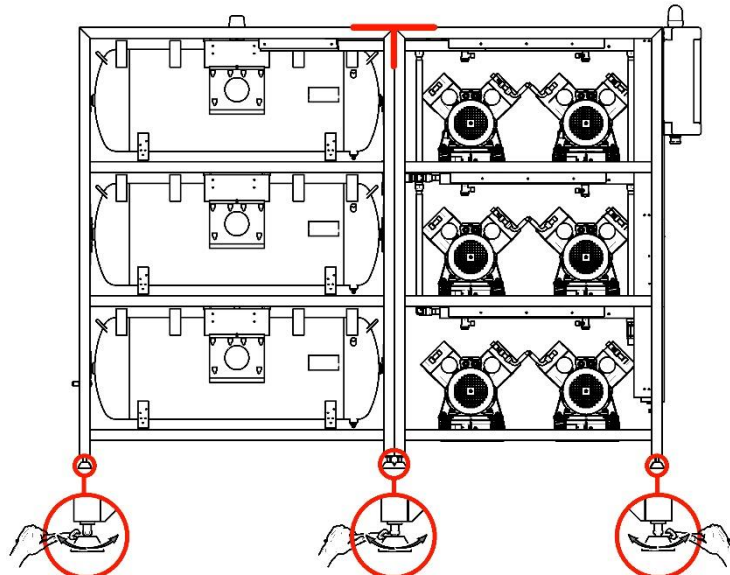

Fig. 7: Frame installation





Prior to installation, ensure that the compressor is free of all transport packaging and stabilizers to avoid any risk of damage to the product.

Remove all devices used to secure the aggregates once the compressor is installed and levelled at the site of final installation.

**Fig. 8: Releasing the air pumps**

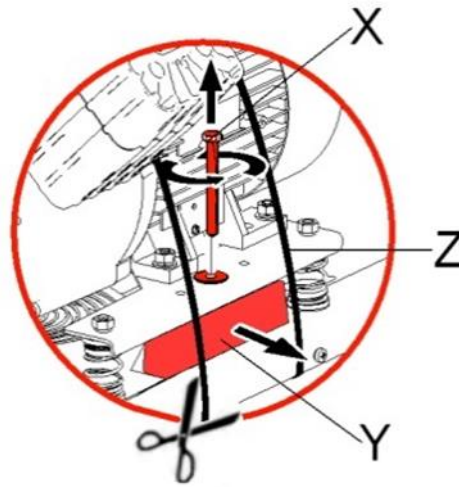

- Remove the transport stabilisers from the air pumps (X, Y, Z) (Fig. 8).
- DK50 6x2VT/M – 12x mounts

#### Assembly of the AD dryer

- Remove the dryer from the packaging.
- Install the dryer in its operating position (Fig. 9).



**At least two persons are needed to handle the equipment.**

Integrated handles are installed on the lower brackets on the product. Each person must grasp the equipment with one hand on a handle and the other behind the dryer chamber when moving the equipment.

**Fig. 9: Handling the dryer**

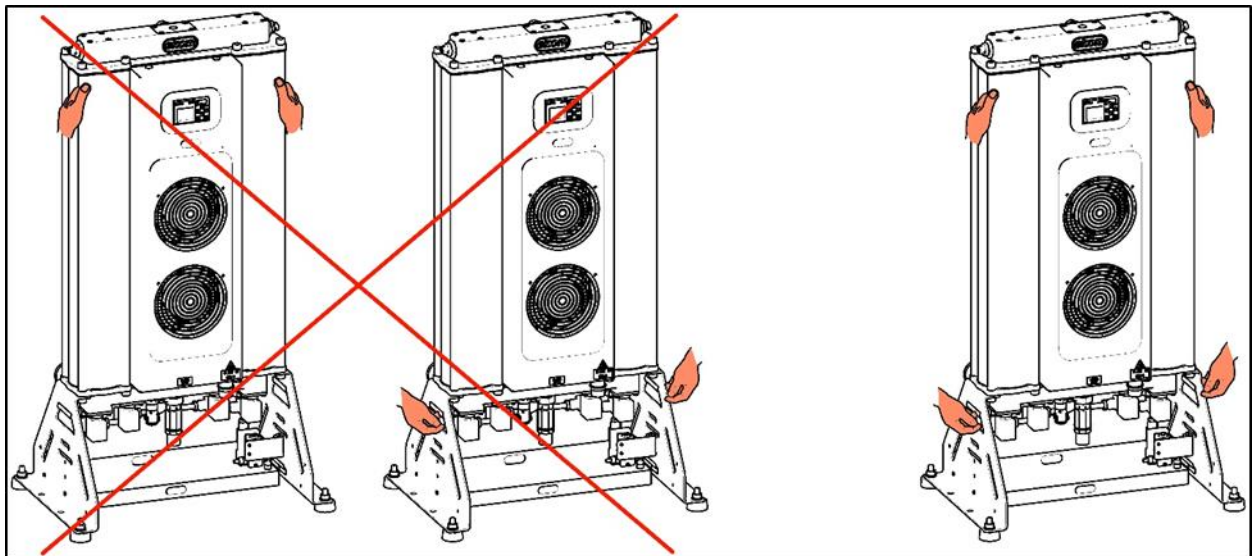

**High temperature hazard**

The placement of air flow impediments upstream or downstream of the cooler is prohibited. The temperature of the internal and external parts of the cooler may be hot and reach hazardous temperatures.

**12. PNEUMATIC CONNECTION**

Connect the compressed air lines at (C) and connect the equipment to the compressed air

system from the G3/4" threaded outlet ball valve.

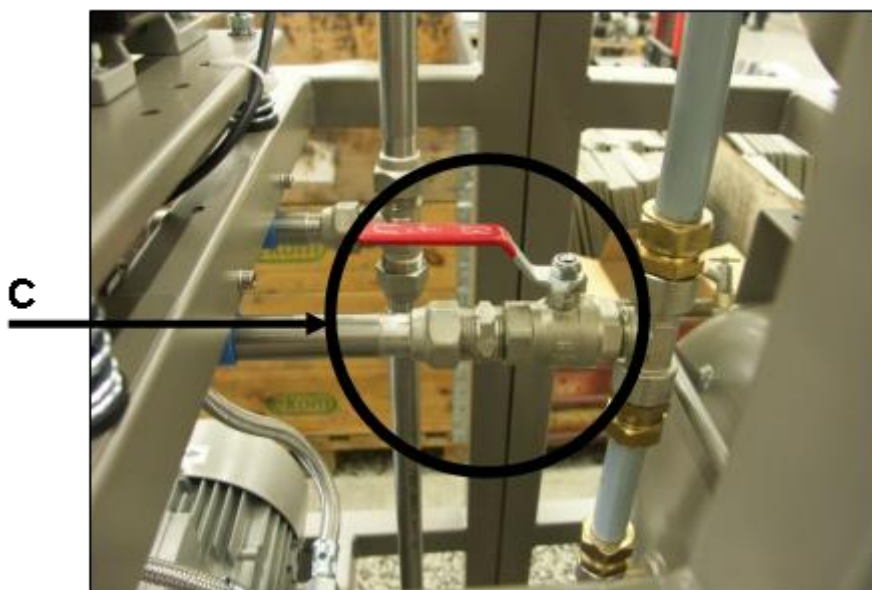

**Fig. 10: Pneumatic connection**

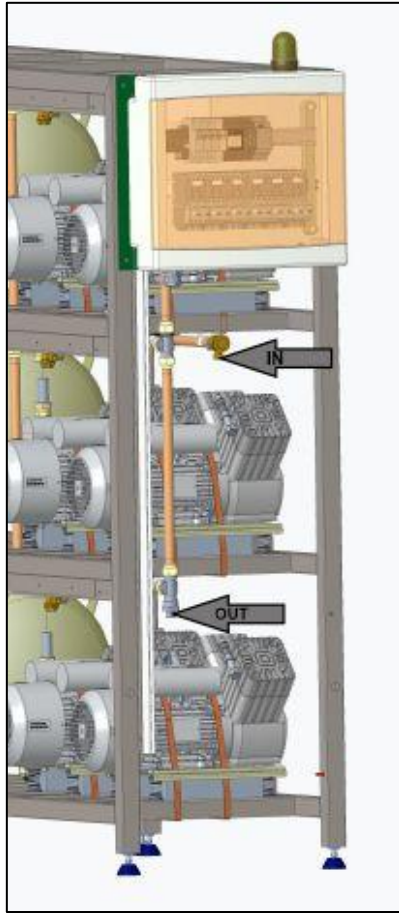

Fig. 11: Pneumatic connection

### AD dryer compressed air inlet

- Connect the outlet (OUT) from the compressor's manifold to the inlet (AIR IN) on the dryer (1).
- Use the 950 mm hose.

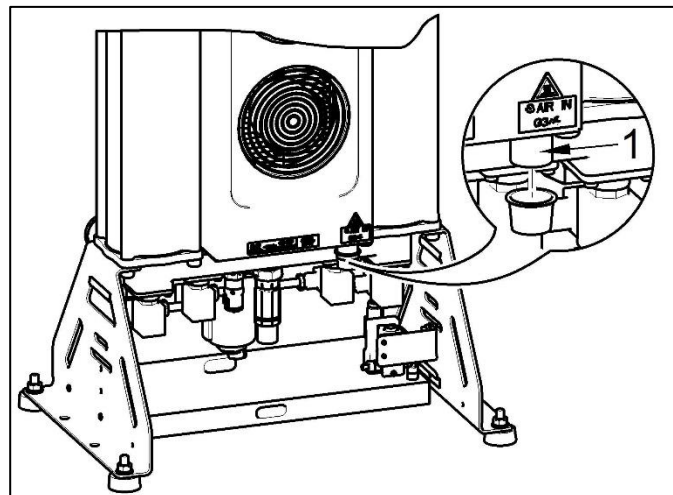

Fig. 12: Compressed air inlet



**Burn or fire hazard! Caution!  
Hot surface!**

When installing the connecting hoses at the inlet to the air dryer, ensure that the temperature is not hazardous if it was to come into contact with an operator or other material.

**AD dryer compressed air outlet**

- Connect the outlet (AIR OUT) from the dryer (1) to the compressor manifold.
- Use the 600 mm hose.

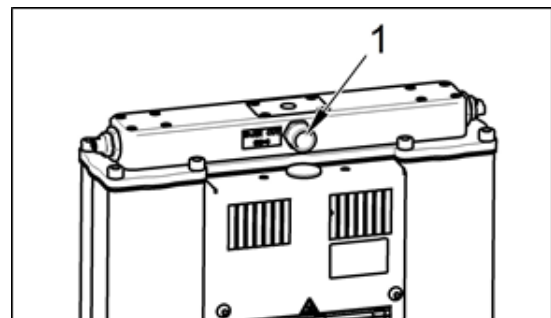

**Fig. 13: Compressed air outlet**

**Condensate outlet from dryer**

- Connect a hose to the outlet (1) from the automatic condensate drain (2) to

drain piping or to the provided collection vessel.

**A noise silencer is recommended when connecting directly to drain piping.**

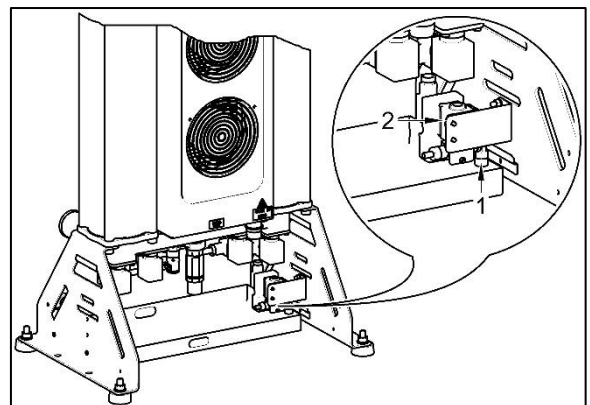
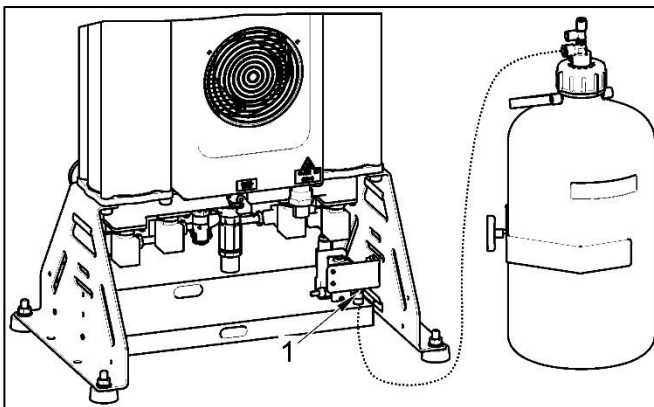

**Fig. 14: Condensate drain**

A G3/4" (F) ball valve is installed on the compressed air outlet from the air tank.

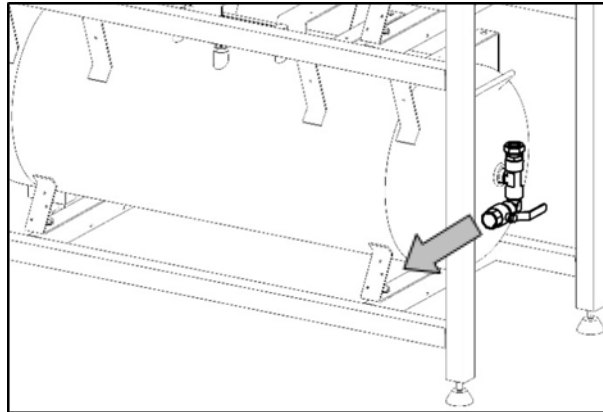

Fig. 15: Air outlet from the air tank



**Potential for damage to pneumatic components.**

Ensure the air hoses are not kinked.

### 13. ELECTRICAL CONNECTION



**Unauthorised interference hazard**

**Only a qualified electrician may install electrical components!**



**The product is delivered without a power cord.**

Cord type (minimum requirements) H05 VV-F\_5G10



**Risk of damage to the device.**

The operator is obliged to provide circuit protection devices for the equipment per the specifications in valid technical standards.



**Risk of electric shock.**

Ensure full compliance with all local electrical codes. The mains voltage and frequency must comply with the data stated on the nameplate on the equipment.

Fig. 16: Connecting the protective PE conductors

- Connect the disconnected PE protective conductors and then the grounding wire after connecting (D).



**Fig. 17: Connecting the electrical cables**

- Connect the disconnected electrical cables (E) to the terminal strips in the electric motor boxes. Insert the cables into the electrical installation trays and enclose with a cover.

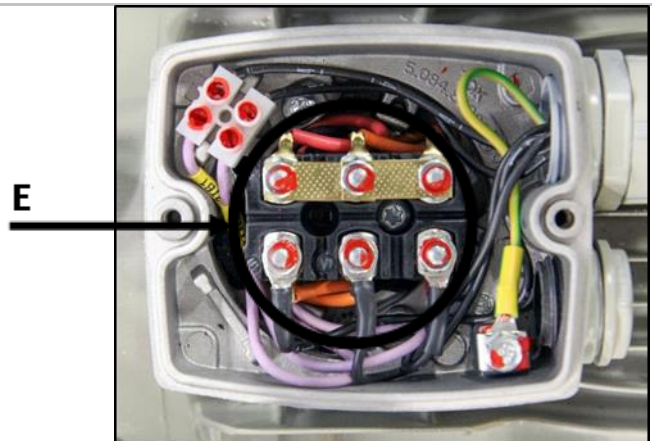

**Fig. 18: Connecting the power cord**

- Connect the TN-S mains to the power supply terminal in the equipment's junction box (F). Connect the electrical components to the mains in accordance with the valid electrical standards and regional regulations.

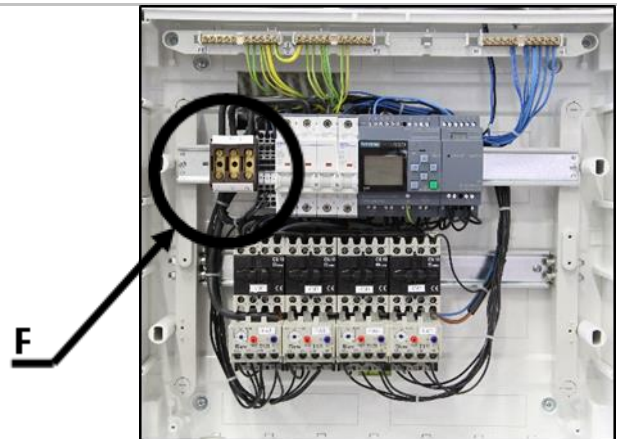

**Fig. 19: Connecting the cable to the pressure switch**

- Connect the loose cord to the pressure switch per the schematic, or Fig. 19, tighten the screws and secure with paint

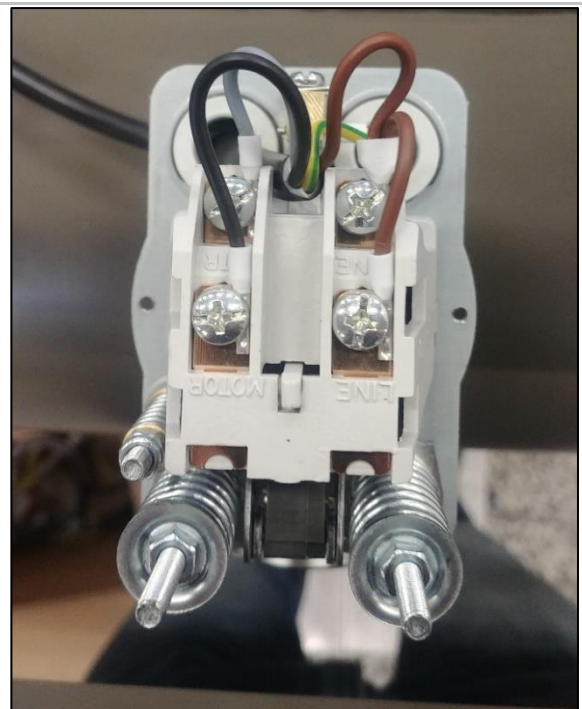

**Fig. 20: Connecting the control harness and power cord from the compressor**

- Connect the dryer control and power cord from the compressor to the receptacle (1).

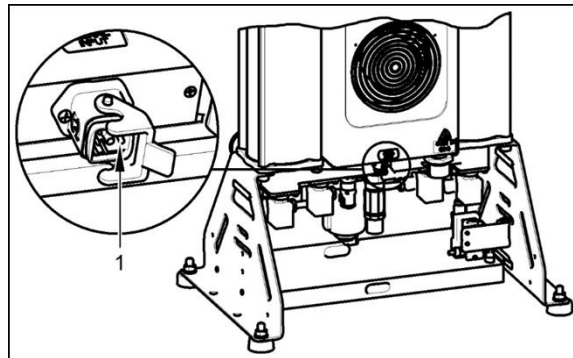

**Fire hazard and risk of electric shock.**

**Ensure the electrical cable does not touch hot parts of the device or connecting hoses.**

#### 14. COMMISSIONING

- Make sure all transport stabilizers were removed.
- Check that all compressed air hose connections are correct.
- Ensure the power cord is properly connected to the mains and the power

cable is connected to the dryer.

- Check to ensure the outlet valve is in the OFF position.



**The compressor is not equipped with a backup power supply.**



15. PNEUMATIC DIAGRAMS

DK50 6x2VT/M

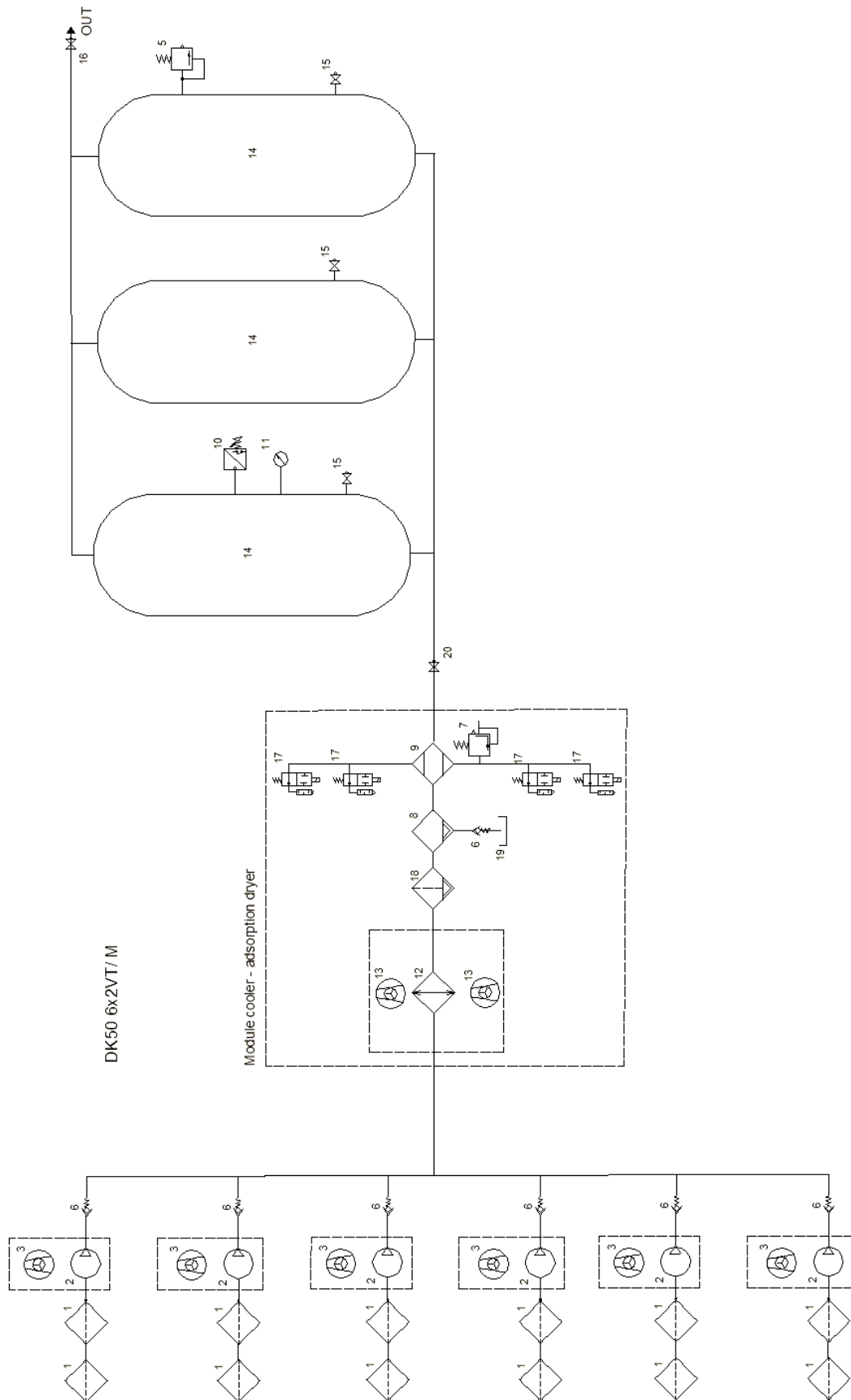

**Description to pneumatic diagrams:**

- |                         |                                   |
|-------------------------|-----------------------------------|
| 1. Inlet filter         | 11. Pressure gauge                |
| 2. Air pump             | 12. Cooler                        |
| 3. Compressor fan       | 13. Cooler fan                    |
| 4. Solenoid valve       | 14. Air tank                      |
| 5. Safety valve         | 15. Condensate drain valve        |
| 6. Non-return valve     | 16. Outlet valve                  |
| 7. Relief valve         | 17. Dryer solenoid valve - outlet |
| 8. Condensate separator | 18. Filter                        |
| 9. Dryer                | 19. Condensate collection vessel  |
| 10. Pressure switch     | 20. Ball valve                    |

**OPERATION**

**ONLY TRAINED PERSONNEL MAY OPERATE THE EQUIPMENT!**



**Risk of electric shock.**

In case of emergency, disconnect the compressor from the mains (pull out the mains plug).



**Burn or fire hazard.**

When the compressor is running, the connecting hose between the compressor and dryer and parts of the dryer and aggregate may be hot enough to burn people or other material.



**Warning - compressor is controlled automatically.**

**Automatic start.** The compressor automatically switches on when the pressure in the air tank drops to the pressure switch's lower limit level. The compressor automatically switches off once the pressure in the tank reaches the shut-off pressure.



**Potential for damage to pneumatic components.**

The working pressure settings for the pressure switch set by the manufacturer cannot be changed. Compressor operation at a working pressure below the switching pressure indicates high air usage (see the Troubleshooting chapter).



**Risk of damage to the dryer.**

The dryer may be damaged if operated at ambient temperatures that are higher than the maximum working temperature (ambient temperature  $>30^{\circ}\text{C}$  or inlet air temperature of  $>100^{\circ}\text{C}$ )



**Required drying performance can only be achieved when following the defined operating conditions.**

Drying performance will decline and the achieved dew point will drop if the dryer is operated at any pressure below the minimum working pressure.

## 16. SWITCHING THE COMPRESSOR

After the pressure switch (6) is activated and circuit breakers FA13 (11) and FA14 (12) are turned to position I, the compressor air pumps sequentially come online (the air pumps in the second column or shelf react with a 2 s delay). Circuit breaker FA13 (11) functions as the main switch.

The air pumps switch on (at  $\leq 6$  bar) and off (at  $\geq 8$  bar) automatically and are controlled by the LOGO! (13) controller and the pressure switch (6) based on compressed air usage.

If the motor surface temperature exceeds 40°C, the temperature switches (10) automatically turn on the compressor cooling

fans, switching them off once the temperature decreases to approximately 32°C.

### 16.1. Controller LOGO!

This controller controls the compressors and dryer valves, monitors and signals alarms (as described below) and displays the number of operating hours. It is composed of a base module and an expansion module. The base module includes a display and the cursor (control) buttons ▲, ▼, ►, ◀, OK and ESC. The expansion module has LED indicators for RUN and STOP.

The parameters of this unit do not require configuration or set up under normal circumstances. The LED indicator on the expansion module should be green once the equipment is connected to its power source and the display should show the current operating hours.

										V 1 . 0 2
										T O W E R n x 2 V T / A D
										R U N H R S 0 h
										S E R V I C E - T O - G O - T O
										M A I N T E N A N C E :
										2 0 0 0 h r s



**The displayed hours are only illustrative.**

Proceed in accordance with Chapter 18 if the indicator is not green.



**The controller is unable to archive time and data if it is disconnected from the power for more than 80 hours. This data must be configured when the equipment is first placed into service or after an extended period in which it has been placed out of service.**

The display shows the main menu.

- press ▲ or ▼ to move the “>” cursor on the display to **Setup..** and press **OK** to confirm

```
>Program
Card..
Setup..
Start
```

The display shows the main menu

- press ▲ or ▼ to move the “>” cursor on the display to **Clock..** and press **OK** to confirm

```
>Clock..
LCD..
Menu lang
```

A menu appears

- press ▲ or ▼ to move the “>” cursor on the display to **Set Clock..** and press **OK** to confirm

```
>Set Clock..
S/W time
Sync
```

A menu appears

- press ▲ or ▼ to select the day of the week
- press ► or ◀ to move the cursor to the next position
- press ▲ or ▼ to set the desired value
- repeat the previous two steps to set the date and time
- confirm by pressing **OK**

```
Set Clock
Su 00:00
YYYY-MM-DD
2003-01-01
```

The following appears:

- Press **ESC** on the controller repeatedly until the main menu appears.

```
>Set Clock..
S/W time
Sync
```

Start the controller program as follows:

- press ▲ or ▼ to move the “>” cursor on the display to **Start** and press **OK** to confirm

```
>Program
Card..
Setup..
Start
```



**Never press OK if the cursor “>” is at Program! This menu provides access to windows with software functional blocks. Changes to the parameters in these blocks have a direct effect on the functionality of the equipment!**

### Alarms and alarm signalling

The equipment automatically checks the functionality of specific parts of the equipment and indicates when maintenance service is needed. The controller determines an alarm as any situation in which the equipment functionality does not match the standard conditions.

The individual alarms are indicated by an alarm signal indicated by an activated HA beacon (10), with one or more alarm messages on the controller's display.

Alarms are classified based on their severity into:

- low priority alarms – signal a maintenance interval  $I = n \times 2000$  hours ( $n = 1, 2, 3, ..$ ) and the equipment supplies air to the central compressed air system using all air pumps; this status is indicated by an activated HA beacon and a message on the display.
- medium priority alarm – triggered by a malfunction in one or more air pumps and the equipment supplies air to the central compressed air system using only functional air pumps; this status is indicated by a flashing HA beacon and message on the display.



The equipment has an intelligent alarm system that generates an alarm signal based on its priority (medium priority alarms have a higher priority than low priority alarms)

### Low priority alarm conditions

The equipment is equipped to monitor and signal maintenance intervals. Maintenance intervals are whole number multiples of 2000 operating hours  $I = n \times 2000$  hours ( $n = 1, 2, 3, \text{etc.}$ ). The maintenance of specific components pursuant to the attached Table 2 must be performed once a maintenance interval is passed. This condition is indicated by an activated yellow HA beacon and an information message on the display.

M	A	I	N	T	E	N	A	N	C	E	T	I	M	E
	C	A	L	L	S	E	R	V	I	C	E			
	P	R	E	S	S		&		H	O	L	D		
	E	S	C	+		▼		3		s	e	c		
	f	o	r		I	N	T	E	R	V	A	L		
					R	E	S	E	T					



**Maintenance intervals are counted from the moment the equipment is first started up.**

This table must be inserted into the compressor maintenance log along with Table 3 in which maintenance work, inspections of the equipment during each maintenance interval and other records regarding the equipment will be recorded.



**This signal from the controller must be cancelled once the maintenance work related to a service interval signal is completed by pressing and holding ESC and ▼ for 3 seconds. Cancelling this signal also resets the maintenance interval to a value of 2000.**

### Medium priority alarm conditions

The equipment is equipped to monitor and signal compressor malfunctions. Such a situation may occur for mechanical or electrical reasons in any of the compressors. This is frequently accompanied by an increase in the current draw. This trips the thermal over current protection in the FA device for the respective air pump or air pumps (the blue button is in position M and the yellow off indicator is not pressed).

Such alarm is signalled by a flashing HA beacon –P1 and an the following message appears on the display:

M	O	T	O	R		F	A	I	L	U	R	E		
	C	A	L	L		S	E	R	V	I	C	E	!	
	P	R	E	S	S		A	N	D		H	O	L	D
	E	s	c	+		▲		3		s	e	c	.	
	f	o	r		A	L	A	R	M					
					R	E	S	E	T					

The beacon will continue to flash after the air pump malfunction is remedied. Turn off the alarm by pressing and holding ESC and ▲ together for 3 seconds.

The flashing beacon function and alarm may be turned off during maintenance work by pressing and holding ESC and ▲ together for 3 seconds. Malfunctions are temporarily indicated by a flashing display on the controller and the subsequent message:

	I	F		D	I	S	P	L	A	Y				
	i	s		F	L	A	S	H	I	N	G			
	t	h	e	n		M	O	T	O	R				
	F	A	I	L	U	R	E		S	T	I	L	L	
		C	H	E	C	K		M	O	T	O	R		
	o	r		R	E	L	A	Y	S		F	A		

This message automatically disappears once the malfunction on the air pump is remedied and it is placed back into service.



Alarm signals have priority over maintenance interval signals. As such, the light will indicate an alarm from any of the air pumps.

Once the alarm is over, the service interval is indicated by the activated HA beacon.

## 17. SWITCHING OFF THE COMPRESSOR

The compressor is switched off using the FA13 circuit breaker by setting it to the "0" position and then disconnecting the compressor from the mains using the mains plug.



**Use Set.. to set the current time.**

- Press ▲ or ▼ to move the ">" cursor on the display to **Stop** and press **OK** to confirm.



**Never press OK if the cursor ">" is at Set Param! Switching to this menu opens windows with software functional blocks. Changes to the parameters in these blocks have a direct effect on the functionality of the equipment!**

Vent the air tanks by disconnecting from the central compressed air circuit and opening the outlet valve (Fig. 1) or the drain valves

**PRODUCT MAINTENANCE****18. PRODUCT MAINTENANCE**

The operator shall secure the completion of repeated testing of the equipment at least once every 24 months (EN 62353) or at the intervals defined by the applicable national regulations. A record of the test results must be made (e.g.: as per EN 62353, Annex G), along with the measurement methods.

The equipment has been designed and manufactured to keep maintenance to a minimum. The following work must be performed to preserve the proper and reliable operation of the compressor.



**Unauthorised interference hazard.**

Repair work outside the framework of standard maintenance (see Chapter 18.1) may only be performed by a qualified technician (an organisation authorized by the manufacturer) or the manufacturer's customer service.

Standard maintenance work (see Chapter 18.1) may only be performed by the operator's trained personnel.

Only use manufacturer-approved replacement parts and accessories.



**Danger of injury or equipment damage.**

Prior to commencing compressor maintenance, it is necessary to:

- check if it is possible to disconnect the compressor from the appliance in order to avoid any risk of injury to the person using the appliance or other material damage;
- turn off the compressor;
- disconnect it from the mains (pulling the cord out of the mains socket);
- vent the compressed air from the air tank.

Prior to commencing dryer maintenance work, first:

- shut off the compressed air supply to the dryer
- turn the main switch on the side of the switchboard to the "0" position;
- check the pressure indicator on the dryer and if there is still pressure, it must first be vented from the dryer chamber.



**Venting compressed air poses an injury hazard.**

Wear eye protection, i.e. goggles, when venting compressed air from the compressed air circuit (air tank) and from the dryer chamber.



**Burn hazard.**

When the compressor is running or shortly thereafter, certain portions of the air pump, the compressor's compressed air system, parts of the dryer and connecting hoses between the compressor and dryer may be hot - do not touch these components.

Allow the equipment to cool down before maintenance, service or connecting/disconnecting the compressed air supply!

The work below may only be performed by trained personnel as follows:



**Turn off the circuit breakers at the switchboard before starting any subsequent maintenance work.**

18.1. Maintenance intervals

Time interval	Once a day	Once a week	Once a year	Once every 2 years	2000 h	4000 h	6000 h	8000 h	10000 h	12000 h	16000 h	20000 h	Chap.	Set of replacement parts	Performed by	
															operator	qualified technician
Check of product operation	x												18.2	-		
Check compressor fans operation		x											Visual check of rotation during air pump operation	-		
Equipment inspection					x	x	x	x	x	x			18.3	-		
Check compressor fans operation					x	x	x	x	x	x			Visual check of rotation during air pump operation	-		
Compressor fan replacement										x				035300016-000		
Replacement of cassettes with adsorbent media									x			x	18.15	603031810-000		
Inspection of electrical connections								x	x	x			18.4	-		
Check the operation of the non-return valves								x					18.9	-		
Check the function of the pressure sensor					x	x	x	x	x	x			18.11	-		

Time interval	Once a day	Once a week	Once a year	Once every 2 years	2000 h	4000 h	6000 h	8000 h	10000 h	12000 h	16000 h	20000 h	Chap.	Set of replacement parts	qualified technician	Perform ed
Relief valve check	x					x	x	x	x	x			18.20	-		
Checking the operation of temperature sensor switching	x					x	x	x	x	x			18.9	-		
Check of safety valve													18.7	-		
Check solenoid valve operation			x			x				x			18.10	-		
Replacement of the dryer's NC solenoid valve												x	18.19	025300117-001		
Inlet filter replacement			x			x	x	x	x	x			18.6	604031761-000		
Replacement of the dryer's internal filters									x			x	18.14	025200322-000		
Replacement of the dryer's silencer									x			x	18.17	025400339-000		
Replacement of the dryer's logic valve ball									x			x	18.16	069000442-000		
Compressor performance check						x	x	x	x	x			18.18	-		
Conduct the "Repeated test" as per EN 62353				x									18	-		
Check pneumatic connections for leaks						x	x	x	x	x			18.3	-		

## 18.2. Check of product operation

- Check air pump condition – the aggregates should be operating normally without excessive vibration or noise. Troubleshoot any problem or call in service personnel if trouble is detected.
- Visually inspect fan operation – the fans must be operating when the aggregates are running. Troubleshoot any problem or call in service personnel if trouble is detected.
- Check to ensure the power cord, the cable for the pressure sensor on the air tank and the connecting compressed air hoses are undamaged. Replace damaged components or call in service personnel.
- Check the ambient temperature at the display – the ambient temperature must be below the temperature limit (40°C). Cool the space if the temperature is high.
- Check for alarm conditions on the display – troubleshoot and remedy all alarms.

## 18.3. Check the compressed air connections for leaks and inspect the equipment

### Leak testing

- Check the compressor's compressed air lines for leaks during operation – pressure supplied by the compressor.
- Use a leak analyser or soapy water to check all joints and connections for leaks. Tighten or reseal the connection where leaks are found.

### Inspecting the equipment

- Check the condition of the compressor air pump for normal operation and noise levels.
- Fan operation check – the fans must

be running during the defined compressor work cycles.

- Check the filter condition – clean dirty filters or replace with new filters.
- Check the solenoid valves in the valve module.
- Check the operation of the automatic condensate drain.
- Call in service personnel if a malfunction is suspected.

## 18.4. Inspection of electrical connections



### Risk of electric shock.

**Inspect the product's electrical connections when the mains are disconnected.**

- Check the mechanical operation of main circuit breaker FA13.
- Check the power cord, conductors connected to the X1 terminal strip and the main circuit breaker FA13 to ensure they are undamaged. Inspect to ensure the connection terminals are properly supported to relieve tension.
- Check to ensure all threaded conductor terminals are tight (on motor circuit breakers FA1-6, contactors KM1-6, etc.). Tighten all loose terminals with a screwdriver.
- Visually inspect the connection of individual cables to the terminal strip X1 (spring clips) and the LOGO! control system (screw terminals).
- Inspect all screw terminals for the protective green and yellow PE grounding conductors in the switchboard, the motor section, the cooling unit and the pressure vessel. Tighten any loose terminals.

## 18.5. Condensate drain



**A wet floor resulting from overflow from the vessel poses a slip hazard.**

Condensate from compressors with air dryers is automatically drained into a vessel to collect condensate.

- Monitor the level in the vessel using the markings (depending on the volume of the vessel), and empty at least once a day.

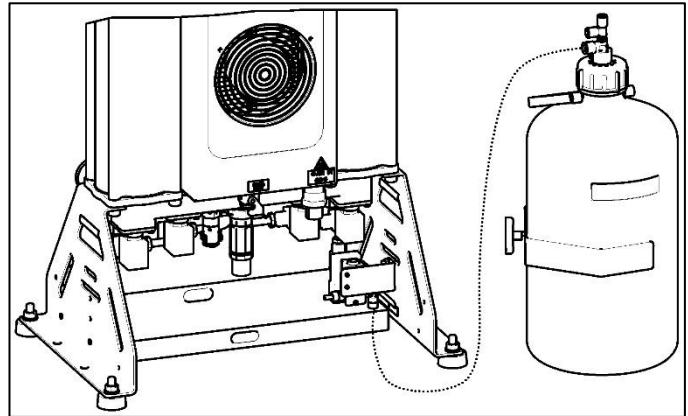

Fig. 21: Check of condensate collection vessel

**18.6. Inlet filter replacement**



The filters located in the compressor air pump enclosure cover must be replaced at defined intervals.

Intake filter replacement:

- Pull out the rubber plug by hand (2).
- Remove the dirty intake filter (1).
- Insert a new filter and replace the rubber plug.

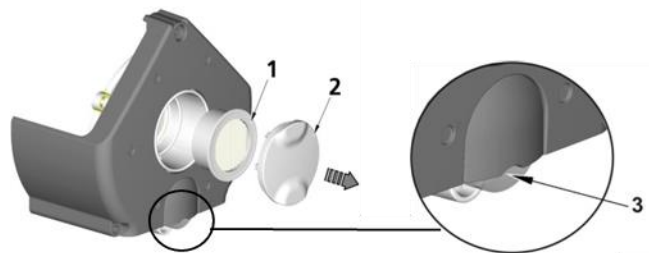

Pre-filter replacement:

- Pull out the pre-filter by hand (3).
- Replace with a new one and insert it back.

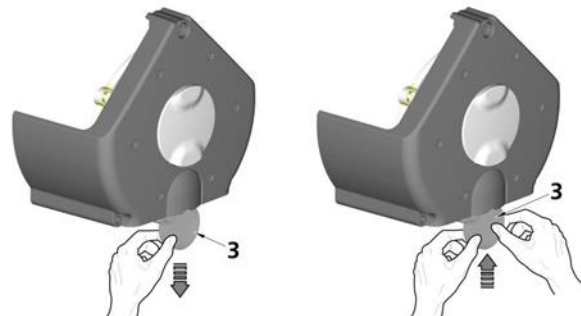

Fig. 22: Inlet filter replacement

**18.7. Check of safety valve**



Damage to the safety valve could cause pressure to rise to hazardous levels.

Never use the safety valve to release the air pressure in the air tank. This could damage the safety valve. The valve is set to the maximum permitted pressure by the manufacturer.

Never adjust a safety valve.



Venting compressed air poses an injury hazard.

Wear safety glasses when inspecting a safety valve.

- Turn the screw on the safety valve several rotations to the left until the safety valve releases air.
- Let the safety valve vent for only a few seconds.
- Turn the screw to the right until it seats, closing the valve.

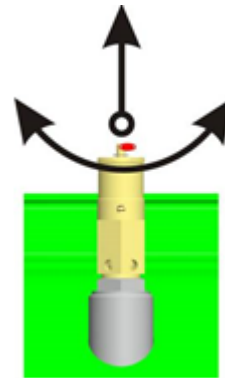

Fig. 23: Check of safety valve

### 18.8. Compressor performance check

- Turn off the compressor using the STOP button.
- Vent the air pressure in the air tank to zero.
- Turn on the compressor using the START button.
- Measure the time to fill the air tank from 0 to 7 bar.
- The measured value must be less than the data provided in the “Technical Data” table.

### 18.9. Check of non-return valve operation

#### Compressed air line:

Check for the proper operation of all non-return valves in the compressed air line and the disconnection of pressure hoses from air pumps.



**One aggregate must be running at all times, while the others may be shut off using the current protection device in the switchboard. No compressed air may leak from the check valves.**

#### Air tank:

Check for proper operation of the non-return valve on the air tank by disconnecting the pressure hose from the valve.



**Check the check valve operation once the air tank has come up to pressure and with the compressor off. No compressed air may leak.**

### 18.10. Check of solenoid valve operation

Check their operation using the “Magnetic indicator” fixture as follows:

- Attach the fixture to the valve coil and if the motors are active at the valve coil, the indicator must rotate and if they are out of inactive, the indicator must not rotate.



Fig. 24: Check of solenoid valve operation

### 18.11. Check the function of the pressure switch

Every pressure switch has a defined hysteresis of ~2 bar. Functionality is checked visually. If the air pumps reach the upper limit, the pressure switch must disconnect the motors from the power. The process is reversed and the motors started at the low pressure limit.

### 18.12. Cleaning and disinfection of the exterior surfaces of the product

Clean and disinfect the exterior surfaces with neutral cleaning products.



**Use of aggressive detergents and disinfectants containing alcohol and chlorides can lead to surface damage and discolouration.**

### AD dryer maintenance

#### 18.13. Venting pressure from the dryer

The equipment is designed to permit the safe venting of pressure within 10 seconds after the compressor is shut off.

If pressure is not automatically vented from the dryer, then the pressure may be vented manually.



**Venting compressed air poses an injury hazard**

**Wearing hearing protection is recommended given the noise generated by the venting process.**



**Shut off the compressed air source before venting pressure from the equipment.**

#### Venting pressure using the display screen

Press ESC+▼ in the display screen to vent pressure from the equipment.

- First, shut off the compressed air source.
- Then press and hold ESC+▼, which will open all the solenoid valves (inlet and regeneration) for 10 seconds and then vent the pressure from the equipment and connected pneumatic circuits and elements that are not separated from the equipment by the check valve.

#### Manual venting of pressure

- Turn off the compressor.
- Open the vent plugs on the outlet module on the equipment (Fig. 25).

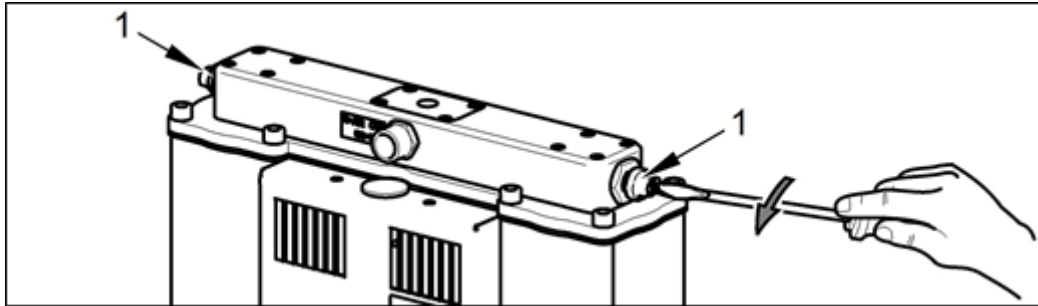

**Fig. 25: Venting pressure from the dryer chambers**

- Disconnect the hose (2) from the lower part of the condensate separator (3) (Fig. 26).

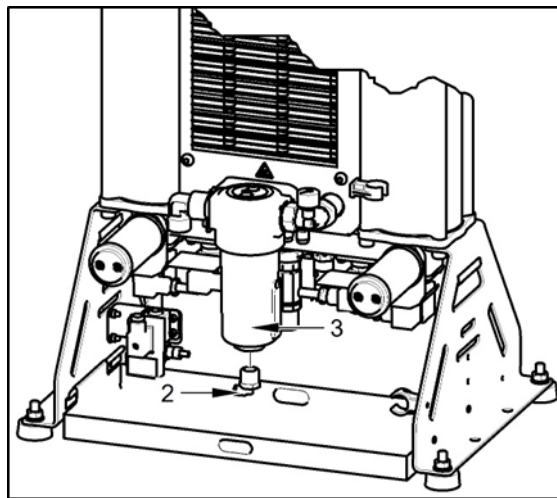

**Fig. 26: Venting pressure from the cooler and condensate separator**

The process of manually venting pressure from the equipment is complete after approximately 2 minutes.

#### 18.14. Replacement of the dryer's internal filters



**Working with pressurised pneumatic components poses a risk of injury.**

**Prior to any work, disconnect the equipment from the mains, shut off the compressor and vent all pressure in the equipment to zero.**

In normal operation, filter replacement must be performed in the upper part of the dryer at the defined interval.



- Turn off the compressor.
- Check the pressure in the dryer.
- If the dryer chambers are under pressure, proceed in accordance with Chapter 18.13.
- Unscrew the 8 screws (1).
- Disassemble the outlet panel (2) on which the filters (3) are mounted.
- Unscrew the dirty filters (3) and replace with new filters.
- Check the seal (4) on the bottom of the outlet module and replace if necessary.
- Reverse the procedure to reassemble.
- Switch on the compressor.
- Check for any dryer leaks.

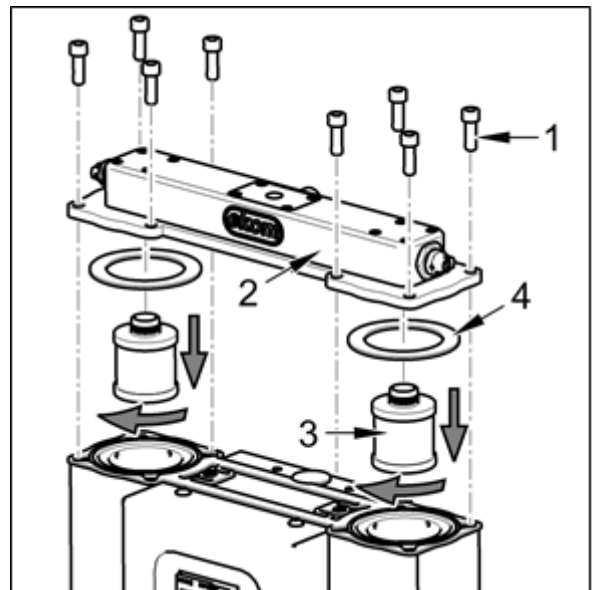

Fig. 27: Replacement of internal filters

### 18.15. Replacement of cassettes with adsorbent media

cassettes with adsorbent media must be performed at the defined interval.

In normal operation, the replacement of the

- Turn off the compressor.
- Check the pressure in the dryer.
- If the dryer chambers are under pressure, proceed in accordance with Chapter 18.13.
- Unscrew the 8 screws (1).
- Remove the outlet panel (2).
- Pull out and replace the cassettes (3) with new parts.
- Check the seal (4) on the bottom of the outlet module and replace if necessary.
- Reverse the procedure to reassemble.
- Switch on the compressor.
- Check for any dryer leaks.

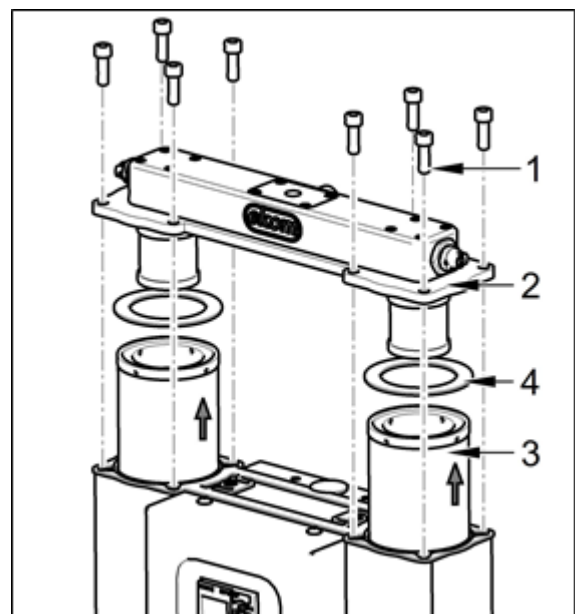

Fig. 28: Replacement of cassettes with adsorbent media

### 18.16. Replacement of the logic valve ball

- Turn off the compressor.
- Check the pressure in the dryer.
- If the dryer chambers are under pressure, proceed in accordance with Chapter 18.13.
- Unscrew the 4 screws (1) and remove the cover (2).
- Remove the ball cover (3).
- Replace the ball (4).
- Check the nozzles (5) and clean as necessary.
- Reverse the procedure to reassemble.
- Check for leaks and the operation of the logic valve and nozzles – check for the cyclical switching of the chambers.

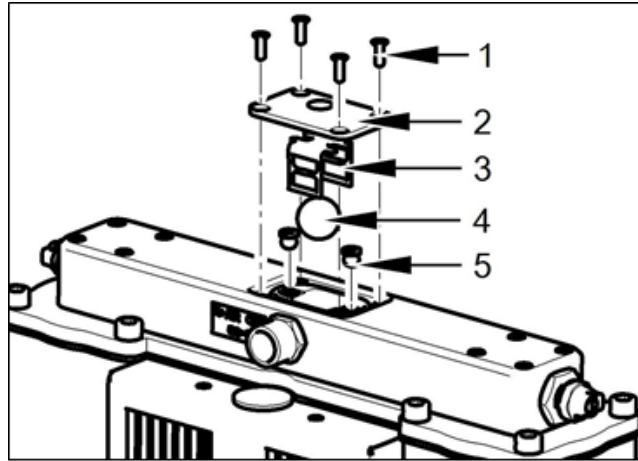

Fig. 29: Replacement of the logic valve ball

### 18.17. Replacement of the dryer's silencer



**Working with pressurised pneumatic components poses a risk of injury.**

**Operating the equipment without silencers generates high levels of noise. Only replace silencers when the equipment is shut down.**

- Unscrew the silencer (1).
- Install a new silencer.

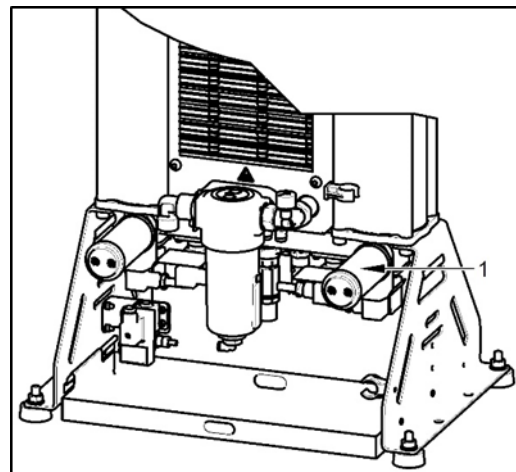

Fig. 30: Replacement of the silencer

### 18.18. Inspecting the cooler and fan

The equipment, in particular the compressor fan, cooler fan, and the cooler, must be kept clean to ensure efficient drying. Remove dust from the surface of the cooling fins and fans by vacuuming or blowing down with compressed air.

### 18.19. Replacement of solenoid valves



**Risk of electric shock.**

**Shut off the compressed air source, turn off the equipment and disconnect it from the mains before working on the equipment.**



**Working with pressurised pneumatic components poses a risk of injury.**

**Disconnect the equipment from the mains and vent the pressure in the equipment and the pneumatic system to zero before working on the equipment.**

In normal operation, the solenoid valves in the bottom of the dryer must be replaced at the defined interval.

- Turn off the compressor.
- Check the pressure in the dryer.
- If the dryer chambers are under pressure, proceed in accordance with Chapter 18.13.
- Unscrew the 1 screw from the valve connector.
- Disconnect the valve connector (1).
- Unscrew the 4 screws (2).
- Remove the solenoid valve (3).
- Remove the valve seal (4-1) from the body.
- Physically clean the valve seat surface to remove any impurities.
- Physically clean the 16 screws (2) to remove the thread locking adhesive.

- Install the solenoid valve (Fig. 32).
- Install the new valve seal (4-1).
- Install the new solenoid valve using the 4 screws (2) and use a thread locking adhesive on the threads of the screws (such as Loctite 243).
- Reattach the solenoid valve connector and attach with a screw.
- Switch on the compressor.
- Check for any dryer leaks.

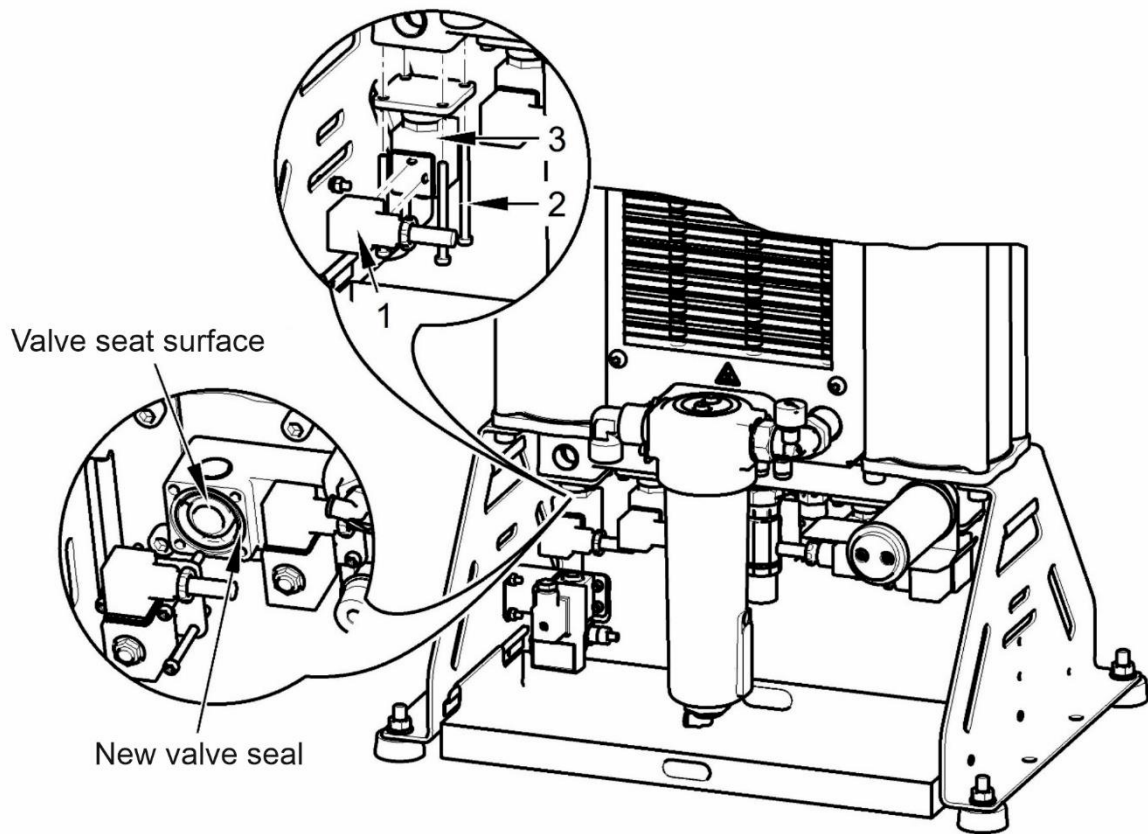

**Fig. 31: Solenoid valve replacement**

### Solenoid valve assembly

Replacement solenoid valves are delivered as disassembled replacement parts. The new valve must be assembled before a solenoid valve is replaced.

- Mount the valve coil (4-5) onto the valve body (4-4) and secure with the

nut (4-6).

- Insert the valve membrane spring (4-3) into the membrane (4-2) and the insert into the assembled valve coil and body assembly.
- Then mount the valve seal (4-1) onto the dryer body.

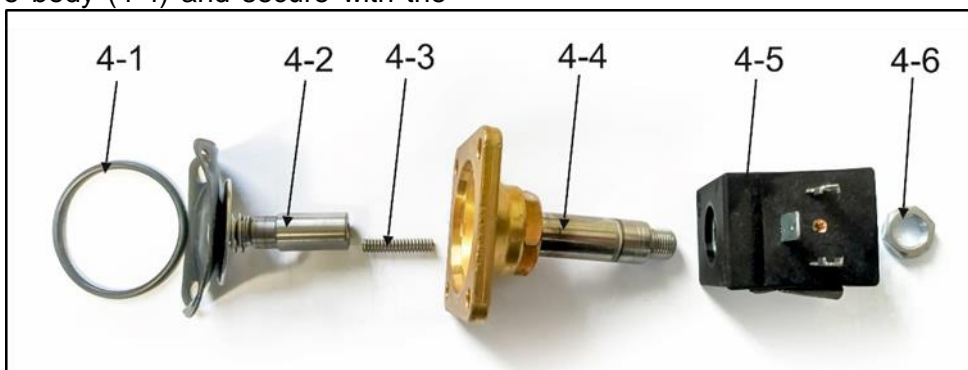

**Fig. 32: Solenoid valve assembly**

**18.20. Pressure relief valve**

The pressure relief valve automatically begins to vent air from the system if the pressure in the compressed air circuit exceeds its pre-set value. The pressure relief valve closes as the pressure drops.



**Working with pressurised pneumatic components poses a risk of injury.**

**Prior to any work, disconnect the equipment from the mains, shut off the compressed air supply, and vent all pressure in the equipment to zero.**



**The pressure in the compressed air circuit can only increase because of an increase in flow resistance in the compressed air lines or as a result of a dryer malfunction (e.g. solenoid valve malfunction), and therefore the repeated opening of the relief valve requires a dryer function check and repairs if necessary!**



**Consultation with the manufacturer is required before any adjustment is made to the relief valve!**

**The outlet openings on the relief valve may not be blocked and the egress of compressed air through them may not be restricted.**

2 Dryer pressure relief valve

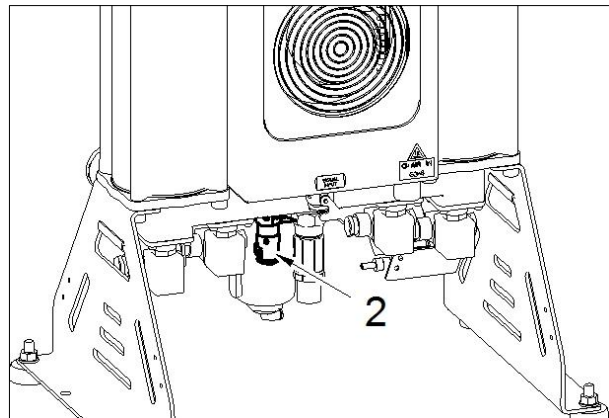

**Fig. 33: Pressure relief valve**

**TROUBLESHOOTING****Risk of electric shock.**

Before interfering with the equipment, first disconnect it from the mains (remove the power socket).



Working with pressurised pneumatic components poses a risk of injury.

Before interfering with the equipment, vent the air tank and the compressed air system to zero pressure.



Troubleshooting may only be performed by a qualified service technician.



Damage to the safety valve could cause pressure to rise to hazardous levels.

Never adjust a safety valve.

Malfunction	Possible cause	Solution
Compressor does not start	Problem with electrical power source	Main breaker is off
	Power loss	Check mains voltage
		Loose terminal in switchboard – tighten
		Check the primary power connection - replace if damaged
Pressure switch failed	Check terminals and operation of the pressure switch - replace if damaged	
Any of the air pumps does not start up (indicator is on)	Loss of power to motor	Check mains voltage
		Check the function of the contactor, and thermal relays - replace if damaged
		Loose terminals at the motor terminal strip - tighten or replace if damaged or broken
	Motor winding shorted, damaged /open thermal protection/ high ambient temperature	Replace the motor / decrease the ambient temperature
	Seized up piston or other moving component (mechanical damage to a moving part)	Replace damaged parts
Controller malfunction	Check controller operation, check to ensure software is present - replace if damaged or upload the correct program	
RUN/STOP indicator is not green	Loss of connection between controller and expansion module	Check connection – replace if damaged
	Power loss	Check mains voltage
		Loose terminal in switchboard – tighten
	Problem with electrical power source	Check the primary power connection - replace if damaged
Controller or expansion module malfunction	Main breaker is off	
Air pumps switch often, even without demand for air	Replace failed controller or expansion module	
	Air leak in compressed air distribution system	Check compressed air distribution system – seal loose joints
	Leaky check valves	Test check valves and clean, or replace if damaged

	Leak through solenoid valves once regeneration is complete	Clean the check valve - replace if damaged
	Leak at pressure sensor and safety valve	Test their function and clean, or replace if damaged
Output of certain air pumps is reduced, extended run cycle	Air pump leaking	Check connections on the air pump for leaks – tighten leaking connections
	Worn piston rings	Replace worn piston
	Gasket between cylinder head and valve plate damaged	Replace gasket, tighten
	Intake filter is plugged	Replace old filter with a new filter
One of the air pumps is noisy (knocking, metal noises)	Damaged motor bearing	Replace damaged bearing
	Damaged piston bearing, piston rod	Replace damaged piston
	Failed (cracked) rubber mount spring	Replace damaged spring with new spring
High ambient temperature causes compressors to switch off in vertical stacks (overheating)	Lack of ventilation in compressor room	Secure suitable ambient conditions
	Cooling fans for aggregates, cooler and enclosure do not work	Defective fans - replace Defective temperature switch - replace
Degraded drying performance – high-pressure dew point (condensed water in the air)	Low operating pressure	Reduce the demand for air, check the output from the compressed air source, fix any leaks in the distribution system
	Regeneration solenoid valve not working	Check coil operation, replace if damaged
	Air regeneration nozzle plugged	Clean or replace the nozzle (see product maintenance)
	Cooling fan not working	Check the power source to the fan Replace damaged fan
	Dirty cooler	Inspect the cooler and clean as necessary
	Silencer plugged at outlet from regeneration valve	Inspect the silencers. Clean or replace the silencer if flow resistance is too high or if heavily soiled.
Dryer emitting high levels of noise	Damaged fan	Replace damaged fan
	Damaged silencer	Replace the silencer
	Air leaking through relief valve at dryer inlet	Check the dryer connection to the mains and dryer connections, check dryer operation, check the dryer's working pressure, and replace defective components.
Air leaking through relief valve at dryer inlet	Compressor running at high working pressure	Check the compressor's working pressure setting
	Dryer inlet solenoid valve not working	Check coil operation, replace if damaged Inspect the condition of the valve - clean the valve or replace if problems persist
	High pressure in equipment resulting from plugged filters	Check the internal filters and accessory filter assemblies. Clean or replace dirty filters.

Once a fault is cleared and after reassembling the dryer, the condensate must be drained from the air tank, then dry the air tank, and the dryer must be regenerated, best when using continuous compressor operation at a

pressure of around 7.0 bar for a period of at least 1 hour.



**Check the moisture content of the air exiting the air tank (see the Technical data chapter) to prevent damage to connected downstream equipment.**

---

## 19. REPAIR SERVICE

Warranty and post-warranty repairs must be done by the manufacturer, its authorized representative, or service personnel approved by the supplier.

### **Attention.**

The manufacturer reserves the right to make changes to the equipment without notice. Any changes made will not affect the functional properties of the equipment.

---

## 20. LONG-TERM SHUTDOWN

If the compressor will not be used for a prolonged time period, it is recommended to drain all condensate from the air tank and the condensate separator. Then turn on the compressor for 10 minutes, keeping the drain

valve on the air tank open (7) (Fig. 1). Switch off the compressor using the main switch, close the condensate drain valve and disconnect the equipment from the mains.

---

## 21. DISPOSAL OF DEVICE

- Disconnect the equipment from the mains.
- Release the air pressure in the pressure tank by opening the drain valve (7) (Fig. 1), release the air pressure from the dryer chambers Fig. 25).
- Dispose of the equipment following all applicable regulations.
- Entrust a specialised company to sort and dispose of waste.
- Worn out components have no negative environmental impact.



---

---

---

---

---

---



# DK50 6X2VT/M

 EKOM spol. s r.o.  
Priemyselná 5031/18, 921 01 PIEŠŤANY  
Slovak Republic  
tel.: +421 33 7967 211, fax: +421 33 7967 223  
e-mail: [ekom@ekom.sk](mailto:ekom@ekom.sk), [www.ekom.sk](http://www.ekom.sk)  
NP-DK50-Nx2VTM-AD-EN-12\_10-2024  
112000481-0001

[www.ekom.sk](http://www.ekom.sk)