

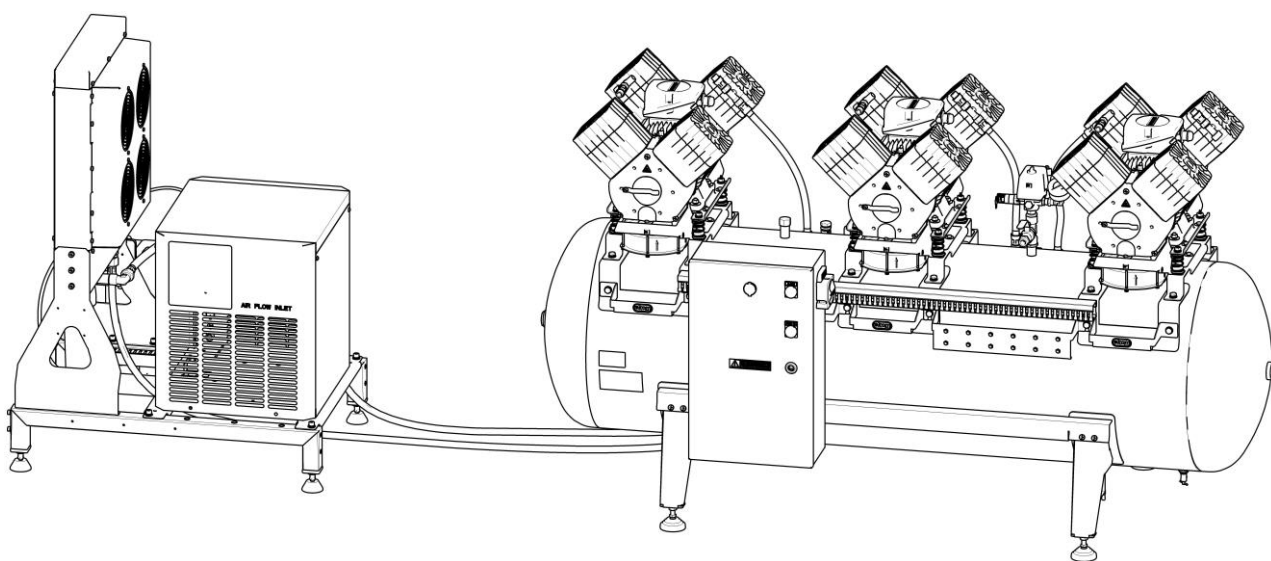

DK50 3X4/M

EN USER MANUAL



CE

COMPRESSOR

DK50 3x4VR/M



EKOM spol. s r. o.
Priemyselná 5031/18
SK-921 01 Piešťany
Slovak Republic
tel.: +421 33 7967255
fax: +421 33 7967223

www.ekom.sk
email: ekom@ekom.sk

DATE OF LAST REVISION

09/2024



NP-DK50 3x4VRM_ED-EN-
7_09-2024
112000284-0001

CONTENTS

IMPORTANT INFORMATION.....	5
1. CE MARKING	5
2. INTENDED USE	5
3. CONTRAINDICATIONS AND SIDE-EFFECTS	5
4. WARNINGS AND SYMBOLS	5
5. NOTICE	6
6. STORAGE AND TRANSPORT	7
7. TECHNICAL DATA.....	8
8. PRODUCT DESCRIPTION	13
9. PRODUCT FUNCTIONALITY	14
10. PNEUMATIC SCHEMATIC	16
OPERATION	17
11. TURNING THE COMPRESSOR ON.....	17
INSTALLATION.....	21
12. CONDITIONS FOR USE	21
13. PLACEMENT OF THE COMPRESSOR	22
14. COMPRESSED AIR CONNECTIONS	23
15. ELECTRICAL CONNECTIONS.....	24
16. COMMISSIONING.....	24
17. SWITCHING THE COMPRESSOR ON	25
18. SWITCHING OFF AND SHUTTING DOWN THE COMPRESSOR	26
MAINTENANCE	26
19. PRODUCT MAINTENANCE.....	26
TROUBLESHOOTING AND REMEDYING PROBLEMS	31
20. SOLVING COMMON PROBLEMS.....	31
21. REPAIR SERVICE.....	33
22. INSTALLATION RECORD	34

IMPORTANT INFORMATION

1. CE MARKING

This product conforms to the requirements of the Regulation (EU) on medical devices (MDR 2017/745) and is safe for the intended use if all safety instructions are followed.

2. INTENDED USE

The compressor is used as a source of clean, oil-free compressed air to power active medical devices where the parameters and properties of the compressed air are suitable for the specific application.



Compressed air supplied by the compressor is unsuitable for use with artificial lung ventilation devices.





















Any use of the product outside its defined uses as defined herein is considered misuse. The manufacturer is not liable for any damages or injury resulting from misuse.

3. CONTRAINDICATIONS AND SIDE-EFFECTS

There are no contraindications or side-effects known.

4. WARNINGS AND SYMBOLS

The following labels and symbols are used in the user manual and on the equipment and its packaging to indicate important details and information:

	General warnings		Swiss Authorised Representative
	Warning		Swiss Importer
	Danger, electric shock hazard		The compressor is remote-controlled and may start without warning.
	Refer to instruction manual		Warning! Hot surface!
	CE mark of compliance		Earth (ground) connection
	Medical device		Terminal for ground connection
	Serial number		Alternating current
	Article number		Handling mark on package – FRAGILE
	Unique Device Identifier		Handling mark on package – THIS WAY UP
			Handling mark on package – DO NOT EXPOSE TO RAIN
			Handling mark on package – TEMPERATURE RANGE



Handling mark on package –
LIMITED STACKING



Manufacturer



Mark on package –
RECYCLABLE MATERIAL

5. NOTICE

The product is designed and manufactured to be safe for the user and its surrounding environment when used in the defined manner. Keep the following warnings in mind. This keeps risks to a minimum.

5.1. General warnings

- The user manual aids in correct installation, operation and maintenance of the product. It is included with the product and must be kept close to it at all times. Careful review of this manual will provide the information necessary for the proper operation of the product as intended.
- The product contains a condensing-type of dryer, which has a separate user manual.
- Only the original packaging ensures protection of the equipment during transport. Save this packaging should you ever have to return the equipment. The manufacturer is not liable for damages caused by faulty packaging when returning a product for transport during the warranty period.
- Use a fork lift truck or similar hoisting equipment for any movement or handling of the product.
- The manufacturer only guarantees the safety, reliability and function of the equipment if:
 - installation, new settings, changes, modifications and repairs are performed by the manufacturer or its representative, or a service provider authorized by the manufacturer.
 - the product is used pursuant to the user manual.

5.2. General safety warnings

- Use and operation of the product must comply with all local codes and regulations.

The operator and user are responsible for following all appropriate regulations in the interests of performing work safely.

- Only the use of original parts guarantees the safety of operating personnel and reliable operation of the product itself. Only use accessories and parts mentioned in the technical documentation or expressly approved by the manufacturer.
- The manufacturer assumes no liability for any damages or other risks if any accessories or parts other than mentioned in the technical documentation or expressly approved by the manufacturer are used. This warranty does not cover damages originating from the use of accessories or consumables other than those specified or suggested by the manufacturer.
- The user must make sure that the equipment is functioning correctly and safely every time it is used.
- The user / operator must be capable of safely using and properly operating the product. The user must be trained to operate the product and must be experienced.
- Create operating regulations for the person operating the product.
- Wear hearing protection when starting the product, during operation and any time it is in operation.
- Operating the product in operating premises that may contain mixtures of flammable gases such as operating rooms or in areas that may contain mixtures of particulate, such as coal dust, is prohibited.
- Flammable materials pose an explosion hazard. Use of the product in wet or damp environments is prohibited.

- The user shall inform the supplier immediately if any problem occurs in direct connection with the operation of the equipment.
 - Any serious incident that has occurred in relation to the device should be reported to the manufacturer and the competent authority of the Member State in which the user and / or patient is established.
- 5.3. Electrical system safety warnings**
- The equipment may only be connected to a properly installed socket connected to earth (grounded).
 - Before the product is plugged in, make sure that the mains voltage and frequency stated on the product are the same as the power mains.
 - Check for possible damage to the product and the connected air distribution system before use. Replace damaged pneumatic and electrical conductors immediately.
 - Immediately disconnect the product from the mains in hazardous situations or when a technical malfunction occurs.
 - During repairs and maintenance, ensure that:
 - product is disconnected from the mains
 - pressure is released from all lines
 - Only the manufacturer, or a qualified specialist trained by the manufacturer may install, modify or upgrade the product itself.
 - Only a qualified electrician may install electrical components.

6. STORAGE AND TRANSPORT

The compressor is shipped from the factory in transport packaging. This protects the equipment from damage during transport.



The original compressor packaging must be used for transport whenever possible. The compressor is shipped in a vertical position and must be secured using transport straps.



Protect the compressor from humid and dirty environments and extreme temperatures during transport and storage. A compressor in its original packaging can be stored in a warm, dry and dust-free area. Do not store near any chemical substances.



Keep the packaging material if possible. If not, please dispose of the packaging material in an environmentally friendly way and recycle if possible. Packaging cardboard can be recycled with paper.



The compressor may only be transported when all air pressure has been vented. Before moving or transporting the compressor, release all air pressure from the tank and hoses and drain condensate from the air tank.



Storing or shipping the equipment in any conditions other than those specified below is prohibited.

Ambient conditions for storage and transport

The equipment may be stored in premises and on vehicles without any traces of volatile chemicals under the following conditions:

Temperature: +0°C to +50°C,
Max. relative humidity: 90%,

7. TECHNICAL DATA

Compressors are designed for dry and well-ventilated indoor environments with the following conditions:

Temperature: +0°C to +40°C,
Max. relative humidity: 70%,
Max. absolute humidity: 15 g/m³.

Tab. 1

Type	DK50 3x4VR/M	
Output at 6 bar	l/min	800
Rated voltage / frequency	V / Hz	3 x 400 / 50
Rated current	A	15
Main circuit protection device rating	A	16/B
Main electrical feeder	mm ²	1.5 mm ²
Enclosure		IP10
Air tank capacity	l	290
Working pressure	bar	6 ÷ 8
Safety valve	bar	10
Noise level	dB	80
Total weight of compressor (net)	kg	337
Weight - compressor	kg	279
Weight - dryer	kg	58
Total compressor dimensions (W x D x H)	mm	2850x800x1040
Dimensions - compressor (W x D x H)	mm	1780x800x1025
Dimensions - ED72 dryer (W x D x H)	mm	760x550x1040
Operating mode		S1 – 100%
Dryer performance (PDP*) with condensing dryer (ED72)		+3°C
Time to fill air tank (from 0 to 7 bar)	s	140
Required cooling air changes in space	m ³ /h	1850
Electrical class		Class I.

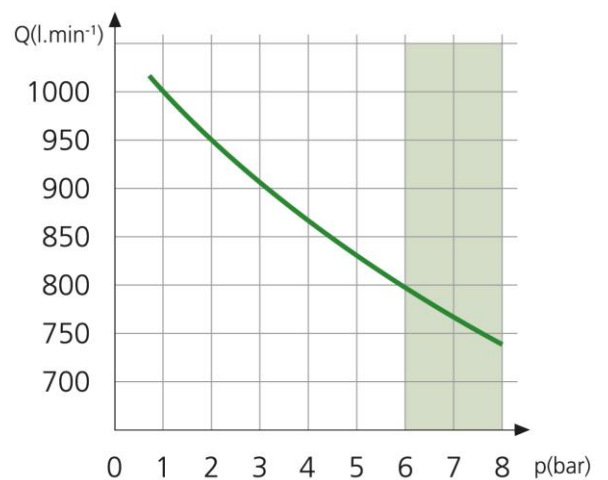

(*) Apply the correction factor for the ED72 dryer

7.1. Free air delivery (FAD) correction due to elevation

FAD correction table

Elevation [MASL]	0 - 1500	1501 - 2500	2501 - 3500	3501 - 4500
FAD [l/min]	FAD x 1	FAD x 0.8	FAD x 0.71	FAD x 0.60

AD reference conditions:

Elevation: 0 MASL

Temperature: 20°C

Atmospheric pressure: 101325 Pa

Relative humidity: 0%

7.2. Dryer performance correction

Reference values for the ED72 dryer

Air temperature at dryer inlet	t_{inlet}	°C	35 (max. 55)
Ambient temperature	t_0	°C	25 (max. 45)
Working pressure	p	bar	7 (max.16)
Pressure dew point	PDP	°C	+3 (-22 atm.)

ED72 dryer correction factors

Correction factor for working pressure							
p (bar)	4	5	6	7	8	9	10
F_{C1}	0.78	0.85	0.93	1.0	1.06	1.11	1.15

Correction factor for temperature of compressed air entering the dryer							
t_{inlet} (°C)	30	35	40	45	50	55	
F_{C2}	1.2	1.0	0.85	0.71	0.58	0.49	

The cooler in use cools the compressed air to a temperature that is ~6°C higher than the ambient temperature.

Therefore: $t_{inlet} = t_0 + 6^\circ\text{C}$

E.g. for an ambient temperature of $t_0 = 24^\circ\text{C}$, $t_{inlet} = 24^\circ + 6^\circ = 30^\circ\text{C} \rightarrow F_{C2} = 1.2$

Dew point correction factor							
PDP (°C)	3	4	5	6	7	8	9
F_{C3}	1	1.04	1.09	1.14	1.18	1.25	1.3

Correction factor for ambient temperature							
t_0 (°C)	25	30	35	40			
F_{C4}	1	0.96	0.92	0.88			

Control calculation for dryer compressed air dew point performance:

$$F_{C3} = \frac{Q_{skut}}{Q_n \cdot F_{C1} \cdot F_{C2} \cdot F_{C4}}$$

Q_{skut} = actual air flow

Q_n = nominal flow through dryer (1800 l/min)

F_{C1} = correction factor for working pressure

F_{C2} = correction factor for temperature entering into the dryer

F_{C3} = dew point correction factor

F_{C4} = ambient temperature correction factor

See the dryer user manual on the CD for more details

Electromagnetic compatibility declaration

Medical equipment needs special precautions regarding electromagnetic compatibility (EMC) and needs to be installed and put into service according to the EMC information provided below.

Guidance and manufacturer's declaration - electromagnetic emissions		
Pursuant to IEC 60601-1-2:2014/AMD1:2020 - Medical electrical equipment - Part 1-2: General requirements for basic safety and essential performance - Collateral Standard: Electromagnetic disturbances		
The equipment is intended for use in the electromagnetic environment specified below. The customer or the user of the equipment should assure that it is used in such an environment.		
Emissions test	Compliance	Electromagnetic environment - guidance
RF emissions CISPR 11	Group 1	The equipment uses RF energy only for its internal functions. Therefore, the RF emissions are very low and are not likely to cause any interference in nearby electronic equipment.
RF emissions CISPR 11	Class B	The equipment is suitable for use in all establishments, including domestic establishments and those directly connected to the public low voltage power supply network that supplies buildings used for domestic purposes.
Harmonic emissions IEC 61000-3-2	Class A	
Voltage fluctuations/ flicker emissions IEC 61000-3-3	The equipment is not likely to cause any flicker, as the current flow is approx. constant after the start up.	

Guidance and manufacturer's declaration - electromagnetic immunity

Pursuant to IEC 60601-1-2:2014/AMD1:2020 - Medical electrical equipment - Part 1-2: General requirements for basic safety and essential performance - Collateral Standard: Electromagnetic disturbances

The equipment is intended for use in the electromagnetic environment specified below. The customer or the user of the equipment should assure that it is used in such an environment.

Immunity test	IEC 60601-1-2 test level	Compliance level	Electromagnetic environment - guidance
Electrostatic discharge (ESD) IEC 61000-4-2	±8 kV contact ±15 kV air	±8 kV contact ±15 kV air	Floors should be wood, concrete or ceramic tile. If floors are covered with synthetic material, the relative humidity should be at least 30%.
Electrical fast transient/burst IEC 61000-4-4	±2 kV for power supply lines ±1 kV for input/output lines	±2 kV 100 kHz repetition frequency Applied to mains connection	Mains power quality should be that of a typical commercial or hospital environment.
Surge IEC 61000-4-5	±1 kV differential mode ±2 kV common mode	±1 kV L-N ±2 kV L-PE; N-PE Applied to mains connection	Mains power quality should be that of a typical commercial or hospital environment.
Voltage dips, short interruption, and voltage variations on power supply input lines IEC 60601-4-11	$U_T=0\%$, 0,5 cycle (at 0, 45, 90, 135, 180, 225, 270 and 315°) $U_T=0\%$, 1 cycle $U_T=70\%$ 25/30 cycles (at 0°) $U_T=0\%$, 250/300 cycles	$U_T \geq 95\%$, 0,5 cycle (at 0, 45, 90, 135, 180, 225, 270 and 315°) $U_T \geq 95\%$, 1 cycle $U_T=70\%$ (30% dipp U_T), 25(50Hz)/30(60Hz) cycles (at 0°) $U_T \geq 95\%$, 250(50Hz)/300(60Hz) cycle	Mains power quality should be that of a typical commercial or hospital environment. The device stops and restarts automatically at each dip. In this case does not occur unacceptable pressure drop.
Power frequency (50/60 Hz) IEC 61000-4-8	N/A	N/A	The equipment does not contain magnetically sensitive components or circuits.
Radiated fields in close proximity per IEC 61000-4-39	N/A	N/A	The equipment does not contain magnetically sensitive components or circuits.

NOTE: U_T is the A.C. mains voltage prior to application of the test level.

Guidance and manufacturer's declaration - electromagnetic immunity

Pursuant to IEC 60601-1-2:2014/AMD1:2020 - Medical electrical equipment - Part 1-2: General requirements for basic safety and essential performance - Collateral Standard: Electromagnetic disturbances

The equipment is intended for use in the electromagnetic environment specified below. The customer or the user of the equipment should assure that it is used in such an environment.

Immunity test	IEC 60601-1-2 test level	Compliance level	Electromagnetic environment - guidance
Conducted RF IEC 61000-4-6	3 Vrms 150 kHz to 80MHz	3 Vrms	<p>Portable and mobile RF communications equipment should be used no closer to any part of the equipment, including cables, than the recommended separation distance calculated from the equation applicable to the frequency of the transmitter.</p> <p>Recommended separation distance</p> $d=1,2\sqrt{P}$ $d=1,2\sqrt{P}, 80 \text{ MHz to } 800 \text{ MHz}$ $d=2,3\sqrt{P}, 800 \text{ MHz to } 2,7 \text{ GHz}$ <p>where P is the maximum output power rating of the transmitter in watts (W) according to the transmitter manufacturer and d is the recommended separation distance in metres (m).</p>
Radiated RF IEC 61000-4-3	3 V/m 80 MHz to 2,7 GHz	3 V/m	<p>Field strengths from fixed RF transmitters, as determined by an electromagnetic site survey ^a, should be less than the compliance level in each frequency range ^b. Interference may occur in the vicinity of equipment marked with the following symbol:</p>
Proximity fields from RF wireless communications equipment IEC 61000-4-3	9 to 28 V/m 15 specific frequencies (380 to 5800 MHz)	9 to 28 V/m 15 specific frequencies (380 to 5800 MHz)	

NOTE 1 At 80 MHz and 800 MHz, the higher frequency range applies.

NOTE 2 These guidelines may not apply in all situations. Electromagnetic propagation is affected by absorption and reflection from structures, objects and people.

^a Field strengths from fixed transmitters, such as base stations for radio (cellular/cordless) telephones and land mobile radios, amateur radio, AM and FM radio broadcast and TV broadcast cannot be predicted theoretically with accuracy. To assess the electromagnetic environment due to fixed RF transmitters, an electromagnetic site survey should be considered. If the measured field strength in the location in which the equipment is used exceeds the applicable RF compliance level above, the equipment should be observed to verify normal operation. If abnormal performance is observed, additional measures may be necessary, such as re-orienting or relocating the equipment.

^b Over the frequency range 150 kHz to 80 kHz, field strengths should be less than 3 V/m.

8. PRODUCT DESCRIPTION

8.1. Delivery includes

- compressor (air pumps with air tank)
- dryer module (condensing) with connecting hoses

DK50 3x4VR/M compressor comprised of (Fig.1):

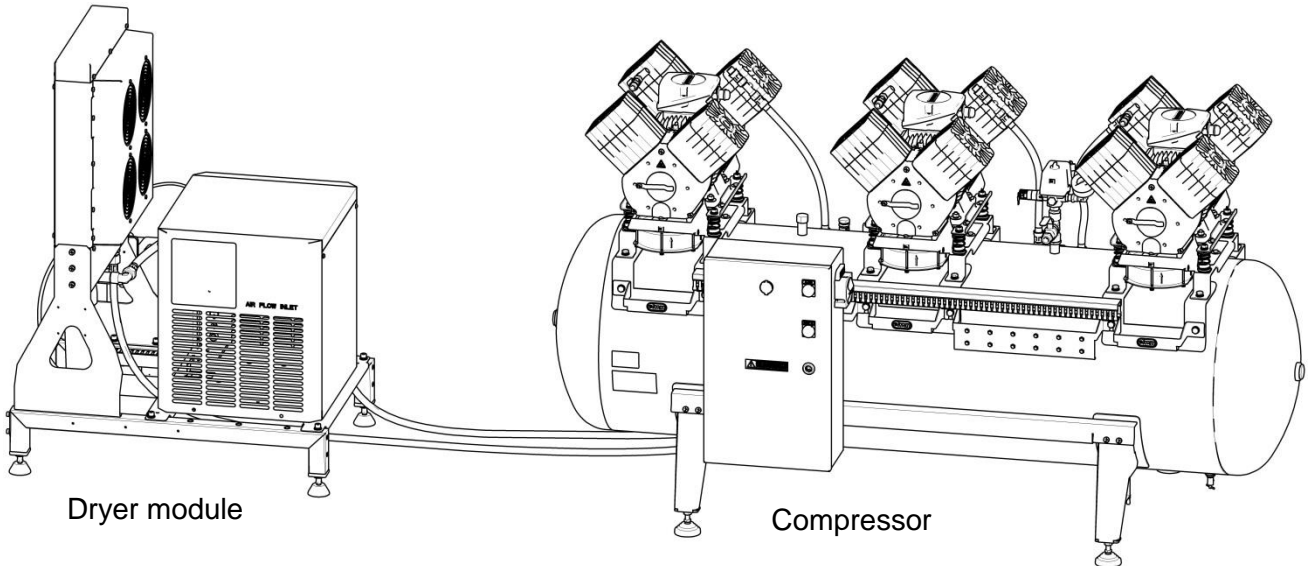

Fig. 1 Compressor

8.2. Accessories

Accessories that are not included in the standard order must be ordered separately.

8.2.1. Set of compressed air outlet filters

The compressor may be equipped with a set of filters if specified. The filter set may be equipped with an air pressure regulator.



Where a different level of air filtration is required, this requirement must be agreed upon with the supplier and specified in the order.

Type	Use	Level of filtration (µm)	Bypass function *	Article number
FS 40F	DK50 3x4VR/M	1	no	604014119-000
FS 40M		1+0.1		604014119-004
FS 40S		1+0.01		604014119-024
FS 40AH		1+AC+HC (0.01)		604014119-005

*) These FS do not contain a filter bypass, which will ensure a continuous flow of air when replacing the filter element. Such a set must be ordered separately.

8.2.2. Filter set regulator assembly

The compressor may be equipped with a pressure regulator of the compressed air outlet if specified. The regulator must be

selected according to the application to the filter set, or separately. The regulator shall ensure constant pressure at the outlet.

Type	Use	Article number
Regulator complete	DK50 3x4VR/M	604014125-000

8.2.3. Filter set brackets



A suitable bracket must be ordered for every filter set.

Type	Use	Article number
Compressor-mounted bracket	DK50 3x4VR/M	603014136-000
Wall-mounted bracket		603014120-000

9. PRODUCT FUNCTIONALITY

Compressor air pumps (1) draw in atmospheric air through the inlet filters (8) and compress it through a check valve (3) and into the common outlet manifold from the air pumps (19). From there, the compressed air proceeds to the cooler (10), in which the compressed air is cooled for the first time and condensate is produced. The air then passes through a water separator (13) and into the condensing dryer (11). This continues to lower the temperature of the air and produces more condensate. The temperature then rises to reduce the relative humidity. The clean, dry air then passes through a check valve (18) and enters the air tank (2). Condensate from the water separator and the dryer is drained off

into a 10 l vessel (14) in the condensate drain kit. The dryer ensures continuous and no-loss drying of the compressed air. Treated compressed air is then ready for additional use in the air tank.

Check the dryer (11) and the air tank check valve (18) to ensure they are operating properly if the pressure relief valve (12) continues to open.



Adjusting the opening pressure of the pressure relief valve or other modification of this valve is prohibited!

Fig. 2 - Product functionality

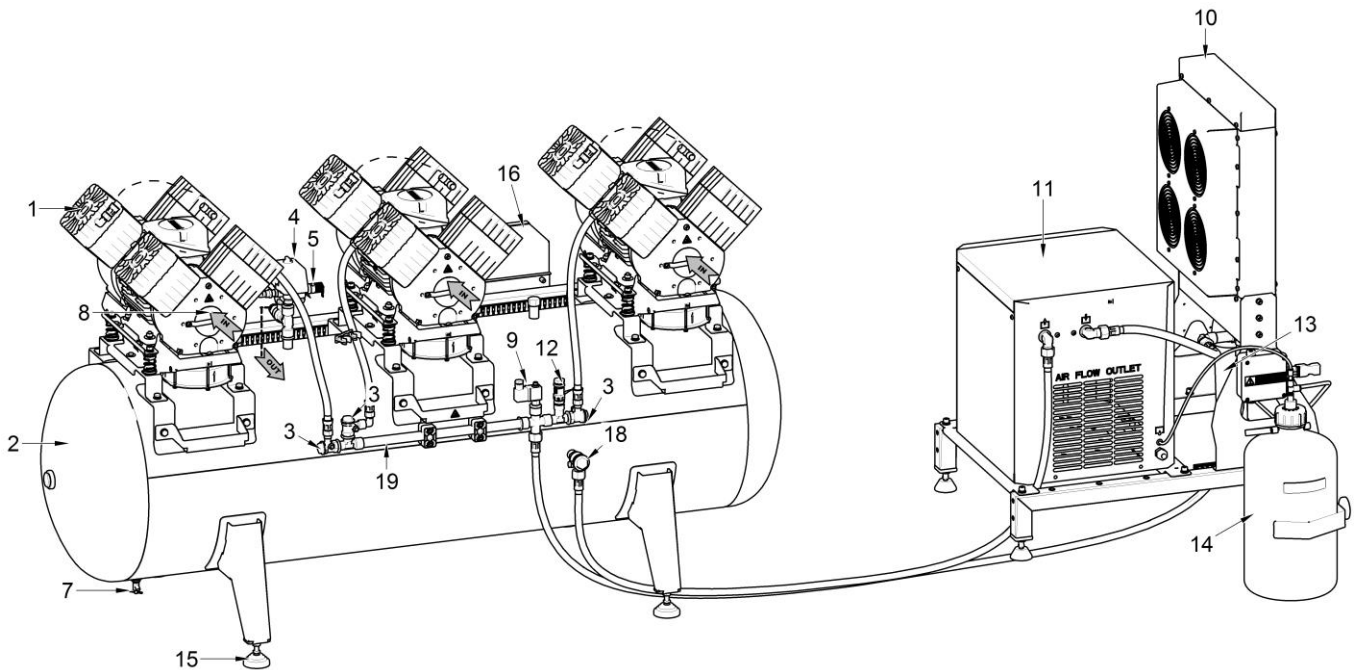
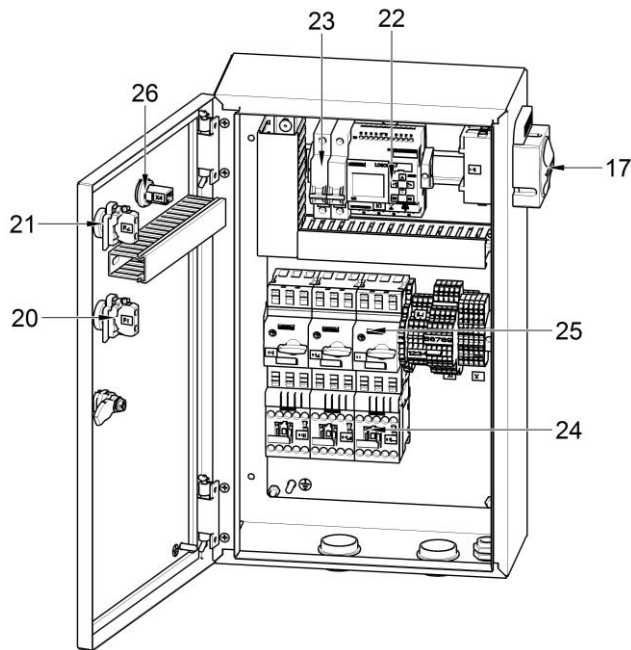
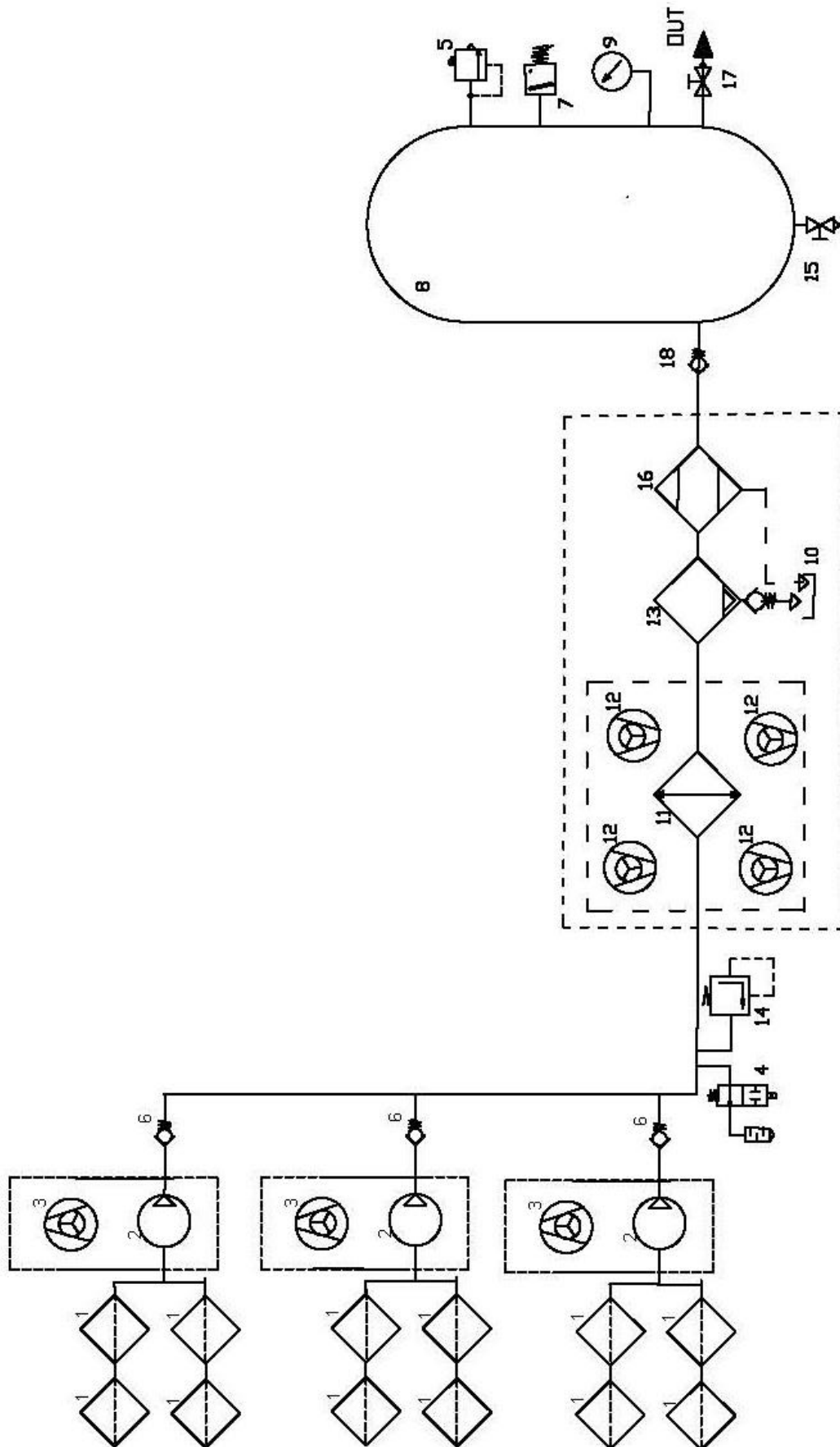

Fig. 3 Distribution box/switchboard

**Legend for Fig. 2 and 3**

- | | |
|---------------------------|-------------------------------------|
| 1. Compressor air pump | 14. Condensate drain kit |
| 2. Air tank | 15. Adjustable foot |
| 3. Check valve | 16. Switchboard |
| 4. Pressure switch | 17. Main switch |
| 5. Safety valve | 18. Air tank check valve |
| 6. Pressure gauge | 19. Common air pump outlet manifold |
| 7. Condensate drain valve | 20. Green indicator |
| 8. Inlet filter | 21. Red indicator |
| 9. Solenoid relief valve | 22. LOGO with hour meters |
| 10. Dryer cooler | 23. Circuit breaker |
| 11. ED dryer | 24. Contactor |
| 12. Pressure relief valve | 25. Motor circuit breaker |
| 13. Water separator | 26. RJ-45 connector |

10. PNEUMATIC SCHEMATIC



Legend

- | | |
|----------------------------------|---------------------------|
| 1 Inlet filter | 11 Cooler |
| 2 Air pump | 12 Cooler fan |
| 3 Fan | 13 Water separator |
| 4 Relief valve | 14 Pressure relief valve |
| 5 Safety valve | 15 Condensate drain valve |
| 6 Check valve | 16 ED dryer |
| 7 Pressure switch | 17 Outlet valve |
| 8 Air tank | 18 Air tank check valve |
| 9 Pressure gauge | |
| 10 Vessel / Condensate drain kit | |

OPERATION



In case of emergency, disconnect the compressor from the mains (turn off the main switch).



The compressor air pump has hot surfaces. Burns may result if contact is made.



During prolonged operation of the compressor, the temperature may increase to over 40°C. At this point the cooling fan automatically switches on. The

fans switch off automatically once the space is cooled to below 32°C.



Automatic start. The compressor automatically switches on when pressure in the air tank drops to the pressure switch's lower limit level. The compressor automatically switches off after reaching the pressure switch's upper limit level.

11. TURNING THE COMPRESSOR ON

(Fig. 1 - 3)

- Rotate the main switch Q10 on the compressor's switchboard to the "I" position, the green POWER ON indicator turns on and the 5 minute interval begins to count down; this interval is needed to bring the ED072 dryer up to standard operating parameters.
- The control module display shows the following screen:

S	T	A	R	T	U	P	D	R	Y	E	R
		P	R	E	S	S	"	O	N	"	
		o	n	t	h	e	D	R	Y	E	R
				a	n	d					
		W	A	I	T	5	m	i	n	s	
				0	0	:	2	7	m		

Press and hold the ON/OFF button on the dryer panel for 1 second. The dryer motors then gradually start

The dryer may be shut off by pressing and holding the ON/OFF button again for 1 second. The dryer motors then switch off to ensure the space inside the dryer itself cools down and the internal pressure balances.

The dryer begins cooling the heat exchanger. Wait 5 minutes, the period counts down on the display.

Once this period expires, the compressor motors activate automatically one by one. The first air pump automatically turns on and the other two air pumps then gradually turn on. The pressure switch monitors the pressure in the air tank. The air pumps operate in automatic mode, and are switched on and off (see the section on working pressures in the Technical Data chapter) by the controller depending on compressed air usage. The compressor motors gradually turn off once the switching pressure is reached.

NORMAL OPERATION

Air pumps operate in automatic mode and are switched on and off based on demand for compressed air. When the pressure in the air tank drops to the switching pressure, the air pumps automatically switch on in a sequence. This ensures that the required pressure is delivered to the air tank in the shortest possible time.

The display shows the normal mode screen during normal operation of the equipment:

M	O	T	O	R	S	:		O	N										
T	O	T	.	H	O	U	R	S										0	h
H	O	U	R	S		R	U	N										0	h
S	E	R	V	I	C	E	:										0	x	

MOTORS ON or MOTORS OFF depending on the current status of the motors.
 HOURS RUN - compressor operating hours
 TIME-TO-GO MN - time to the next maintenance / service work
 SERVICE – number of 2,000 h service calls.
 TOT:HOURS – total time the compressor has been energised

SHUTTING DOWN THE COMPRESSOR

Rotate switch Q10 to the “O” position to disconnect the compressor from the mains. The green P1 indicator should turn off.

11.1. Controller – operation and alarms

The controller controls the air pumps, monitors their operation, analyses faults, reports alarms and indicates when maintenance is required after defined intervals are met.

Alarms and service intervals are shown on the display. The control panel on the controller has four cursor buttons▲, ▼, ►, ◀, and ESC and OK buttons.

11.1.1. Equipment operation

The normal mode display is typically shown when the equipment is running.

Once the service interval is reached (2,000 hours, and indicated with the red P2 (ALARM) indicator), a service technician completes maintenance in the required scope (see Chapter 18.1) and then resets this interval by pressing ESC+► once the maintenance work is completed.

11.1.2. Alarms



The equipment has an intelligent monitoring system that generates an alarm signal based on priority (medium priority alarms have higher priority than low priority alarms)



Alarm signals have a higher priority than maintenance/service interval signals.

The maintenance / service interval is measured from the first time the equipment is energised. All alarms are accompanied by a blinking red P2 (Alarm) indicator.

Low priority alarm conditions

- Expiry of defined maintenance / service interval.

This alarm activates once the 2,000 hour maintenance / service interval expires. The display shows the following details:

S	E	R	V	I	C	E		A	C	C	O	R	D	.						
T	O							I	N	S	T	R	U	C	T	I	O	N	S	
								F	O	R										
T	I	M	E	t	O	G	O	M	N									0		
R	E	S	E	T	:	A	L	T	+	►							5	s	e	c

SERVICE ACCORD. TO INSTRUCTIONS FOR USE

TIMEtoGO MN – time to complete compressor maintenance

RESET: ESC+▶ 5 sec. – reset the maintenance interval by pressing and holding ESC+▶ for at least 5 seconds.

The number of maintenance intervals conducted every 2,000 hours is shown in the bottom row.

The display flashes orange.

This indicates the new maintenance interval has been set on the controller from this time forward.

Note: Only service personnel are authorised to configure a new service interval



Any maintenance or service work must be recorded in the compressor’s service log.

Medium priority alarm conditions

- Air pumps malfunction

A	L	A	R	M	!					
O	V	E	R	L	O	A	D			
C	A	L	L	S	E	R	V	I	C	E
Q	1	=	O	K						
Q	2	=	O	K						
Q	3	=	F	A	U	L	T			

The display shows a message (FAULT) and the P2-ALARM indicator is flashing.

This indicates which air pump is not running (a motor circuit breaker (Q1 - Q3) is tripped due to current overload). The display flashes red. The other air pumps are working normally. The screen deactivates and the screen for normal operation is shown once the malfunction is remedied and the motor circuit breaker is manually placed back in the “ON” position.

The compressor only supplies compressed air to the central line through the functional air pumps.

The compressor supplies air to the compressed air system as needed and without restriction

Correct configuration of the new interval is confirmed when the text “CORRECT” appears in the lower right row

- Fault - motor winding temperature fault.

E	R	R	O	R	!							
S	T	A	T	O	R	W	I	N	D	I	N	G
C	A	L	L	S	E	R	V	I	C	E	!	
M	O	T	O	R	1	=	O	K				
M	O	T	O	R	2	=	F	A	U	L	T	
M	O	T	O	R	3	=	O	K				

The message on the display (FAULT) and blinking P2-ALARM indicator indicate which of the air pump motors has malfunctioned (open thermal overload switch (B11 - B13) inside the motor winding (M1 - M3)). The malfunction in the air pump may be mechanical or electrical.



Once the malfunction is remedied (cooling, repair or replacement; the thermostat must be on), the P2 indicator stops flashing and the display no longer shows the alarm.

Medium priority alarm signals have priority over maintenance interval signals.

As such, the display will show a medium priority alarm if there is a malfunction involving any of the air pumps.

ETHERNET CONNECTION

The compressor may be connected to an Ethernet 10/100 M network via the controller as follows:

1. Use the RJ-45 connector (on the switchboard door) to connect a cable to the Ethernet network.
2. The user shall then request IT staff to connect the compressor to the user's Ethernet network. The equipment's default IP addresses are: BM=192.168.0.3, TDE=192.168.0.2, sub-mask =255.255.255.0.
or
3. The user shall request the configuration of IP addresses (specific or requested) from the manufacturer before the compressor is shipped, or configure the IP addresses (specific or requested) based on the manual (see the service manual) or via the compressor manufacturer's technical support for such purposes.

Web server

The controller has an integrated Web Server function that facilitates compressor monitoring via a PC, smartphone or tablet using a conventional web browser (Mozilla, Opera, Safari, Google Chrome, etc.)

The process for logging into the Web Server function once the compressor is connected to an Ethernet network is as follows:

Open the web browser on a PC, smartphone or tablet and enter the IP address of the controller (192.168.0.3)

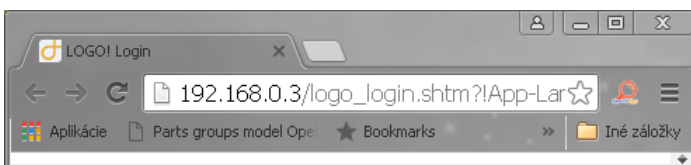

Enter the password "LOGO" and click on the "LOG on" button.

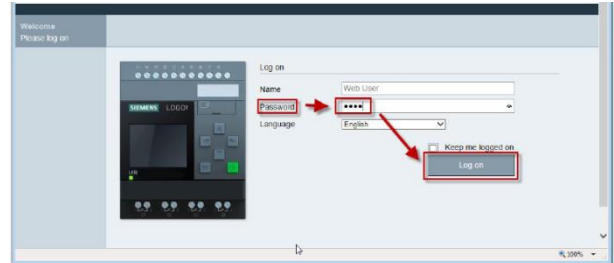

After logging in, the browser displays the first screen showing the system information for the controller itself: module generation, model, firmware (FW), IP address and activity status.



Click on the "LOGO! BM" function in the browser to display the current virtual status of the BM text display screen. Navigate through the screen using the cursor keys the same as on the real display

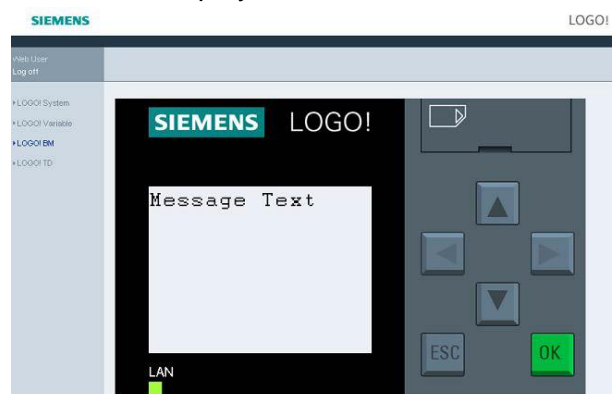

INSTALLATION

12. CONDITIONS FOR USE

The compressor may only be installed and operated in dry, well-ventilated and dust-free areas.

The compressor must be installed so that it is accessible at all times for operating and maintenance. Please ensure that the nameplate on the device is readily accessible.

The compressor must stand on a flat, sufficiently stable base (be aware of the weight of the compressor, see Technical Data).

The compressor on the operator's side must be at least 70 cm from the wall to allow air flow for cooling purposes and to ensure the safety of the operator and maintenance personnel.

 **Operating the equipment in areas in which flammable mixtures may be present is prohibited, such as in operating rooms, coal storage areas, etc. Flammable materials pose an explosion hazard.**

 **Replace all damaged electrical cords and air hoses immediately.**

The power cord may not show signs of stress and must be kept without tension (putting any objects on it is prohibited) and subjecting the cord to external heat in any form is prohibited.

 **You may notice a “new product” odour when you first place the product into service (for a short period of time). This odour is temporary and does not impede the normal use of the product. Ensure the space is properly ventilated after installation.**

Environmental requirements:

Temperature: $+0^{\circ}\text{C}$ to $+40^{\circ}\text{C}$,
Max. relative humidity: 70%,
Max. absolute humidity: 15 g/m^3 .

Approximately 70% of the electrical energy used by the compressor air pumps is converted to heat and therefore the rooms in which a compressor assembly is installed must have additional ventilation to provide sufficient air exchange for cooling purposes (see the technical data)

 **Caution! Hot surface!** Portions of the compressor air pump may be hot and reach hazardous temperatures during compressor operations that may harm materials or operating staff.

Fire hazard!

Recommended flow of cooling air:
 DK50 3x4VR/M - 1850 m³/h

Applies for continuous operation and cooling air temperature of 20°C

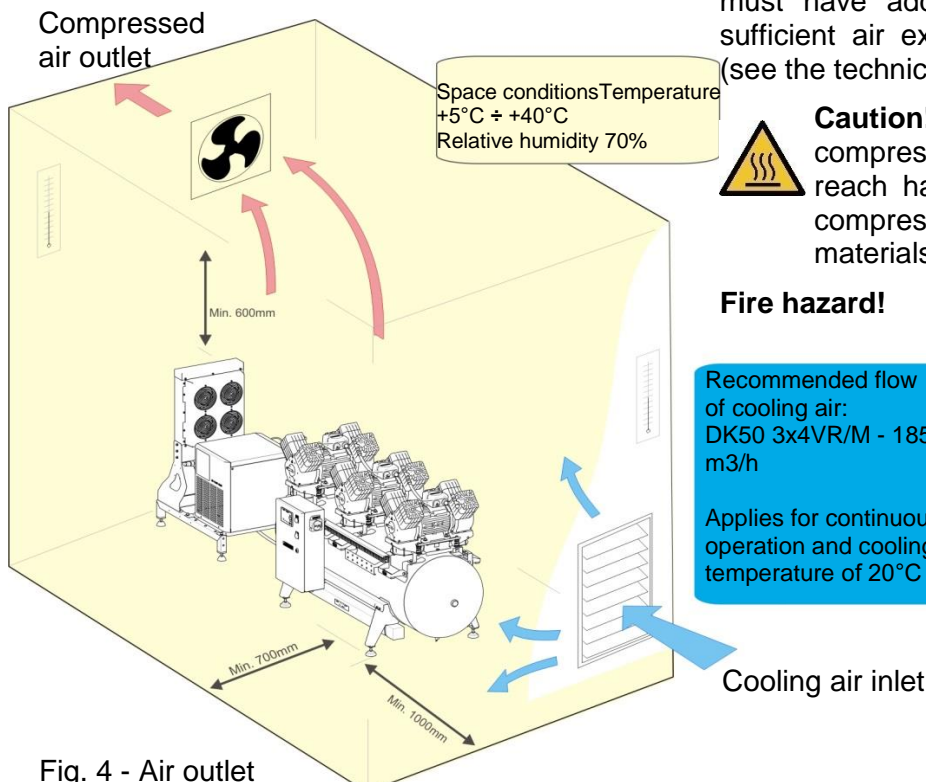

Fig. 4 - Air outlet

13. PLACEMENT OF THE COMPRESSOR

Only a trained and qualified technician may install the product.



Unpack the compressor assembly (compressor and dryer module) from the packaging and remove the transport anchors from the pallet. Fixation of the compressor and dryer module to the pallet.

13.1. Handling

Use a fork lift truck or similar hoisting equipment to handle and position the product.

- Position the compressor module at the site of installation. (Fig. 5)
- Remove the transport beam (1).
- Remove the transport stabilisers from the air pumps. (Fig. 6)

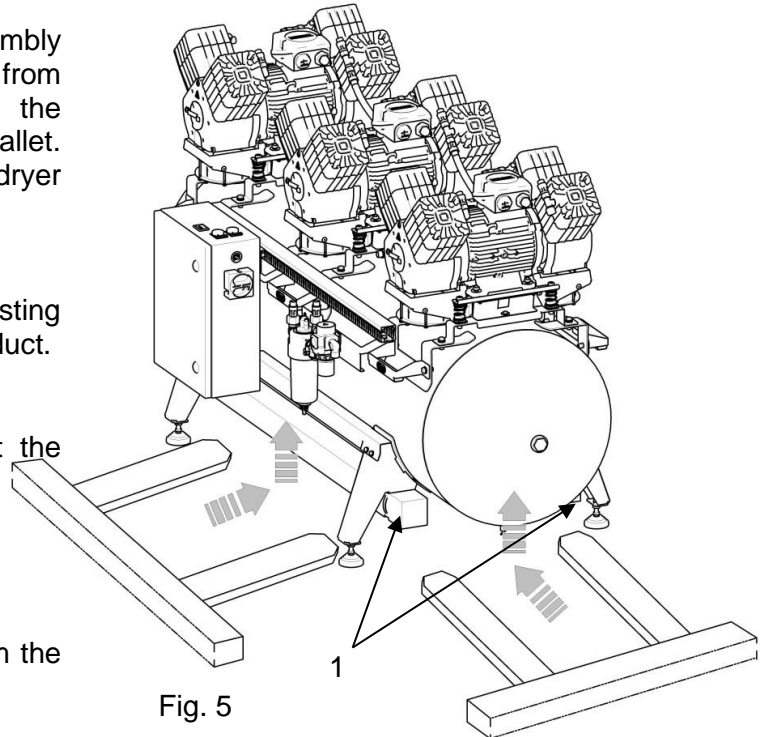

Fig. 5



Remove all devices used to secure the air pumps once the compressor assembly has been installed and mounted at the site of final installation!

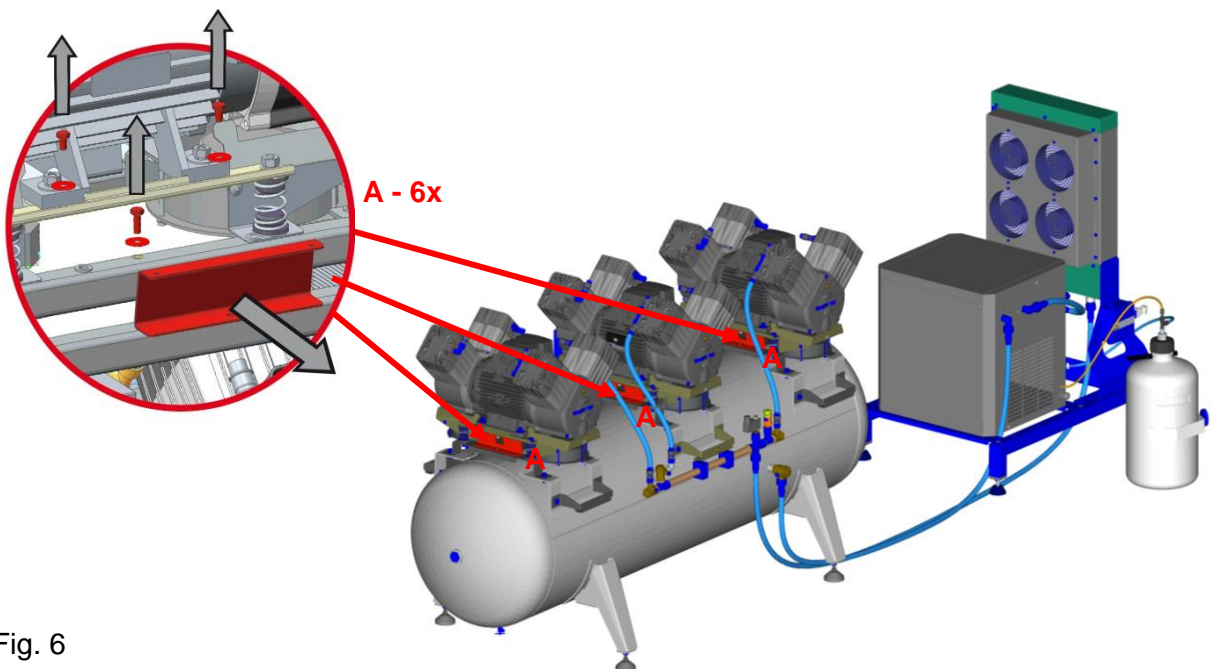

Fig. 6

Releasing the air pumps
DK50 3x4VR/M - 6 mounts

14. COMPRESSED AIR CONNECTIONS

- Connect the compressor assembly using the hoses (included with delivery). (Fig. 7)

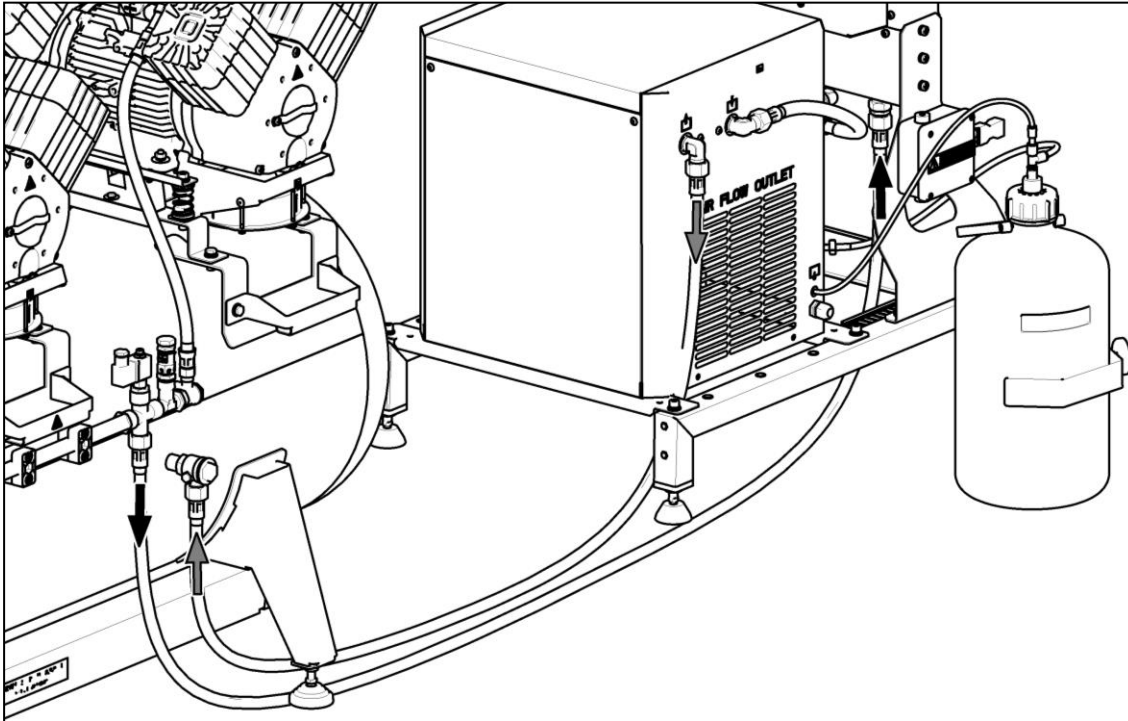

Fig. 7

- Connect the hoses from the water separator and the condensate drain from the dryer to connectors at the canister valves. (Fig. 8)

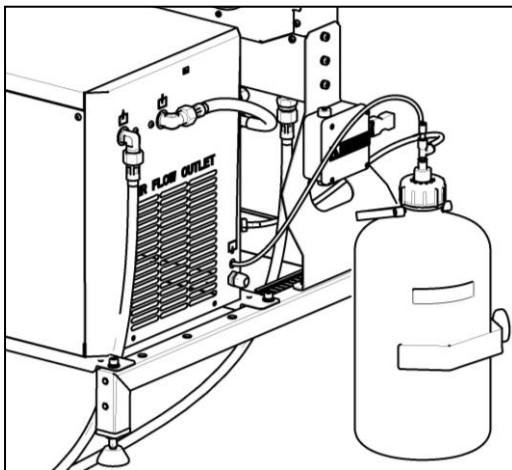

Fig. 8

- A G1/2" female threaded end ball valve is installed on the compressed air outlet from the air tank (Fig. 9)

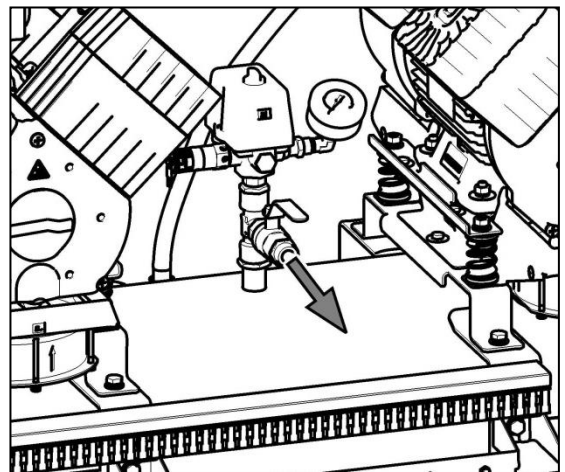

Fig. 9

15. ELECTRICAL CONNECTIONS



Only a qualified electrician may install electrical components!



The operator is obliged to provide circuit protection for the equipment per the specifications in valid technical standards

- Connect the compressor module to the dryer module using the W22 cable (Fig. 10).

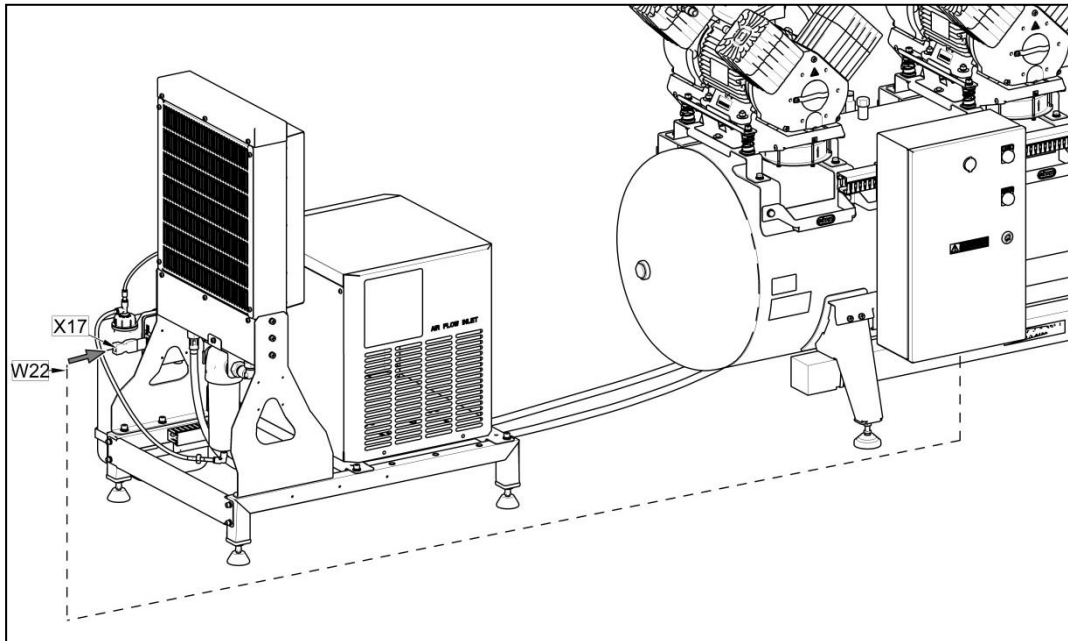

Fig.10

16. COMMISSIONING

Make sure all transport stabilizers were removed.
Check that all compressed air hose connections are secure.

Check to ensure the power cord is properly connected to the mains.
Check to ensure the outlet valve is in the OFF position.

17. SWITCHING THE COMPRESSOR ON

(Fig. 1 - 3)

- Rotate the main switch Q10 on the compressor’s switchboard to the “I” position, the green POWER ON indicator turns on and the 5 minute interval begins to count down; this interval is needed to bring the ED072 dryer up to standard operating parameters.
- The control module display shows the following introductory screen:

S	T	A	R	T	U	P	D	R	Y	E	R
		P	R	E	S	S	"	O	N	"	
		o	n	t	h	e	D	R	Y	E	R
				a	n	d					
		W	A	I	T	5	m	i	n	s	
				0	0	:	2	7	m		

PRESS “ON” on the DRYER and WAIT 5 minutes.

Press and hold the ON/OFF button on the dryer panel for 1 second and wait 5 minutes. The dryer motors then gradually start

The dryer may be shut off by pressing and holding the ON/OFF button again for 1 second. The dryer motors then switch off to ensure the space inside the dryer itself cools down and the internal pressure balances.

The dryer begins cooling the heat exchanger. Wait for 5 minutes, this time is shown in the bottom row of the display

 Check all air line connections and check for compressed air leaks. Remedy all leaks that are identified.

Slowly open the outlet valve to the ON position. The compressor assembly starts and runs until pressure in the entire compressed air system stabilises. The air pumps then gradually turn off at the switching pressure.

Once this period expires, the compressor motors activate automatically one by one.

The first air pump automatically turns on and the other two air pumps then gradually turn on. The pressure switch monitors the pressure in the air tank.

Air pumps operate in automatic mode and are switched on and off based on demand for compressed air. When the pressure in the air tank drops to the switching pressure, the air pumps automatically switch on in a sequence. This ensures that the required pressure is delivered to the air tank in the shortest possible time.

The display shows the normal mode screen during normal operation of the equipment:

M	O	T	O	R	S	:	O	N			
T	O	T	.	H	O	U	R	S		0	h
H	O	U	R	S	R	U	N			0	h
T	I	M	E	-	T	O	-	G	O	M	N
		2	0	0	0	h	o	u	r	s	
S	E	R	V	I	C	E	:			0	x

MOTORS ON or MOTORS OFF depending on the current status of the motors
 TOT.HOURS – total time the compressor has been energised
 HOURS RUN - air pumps operating hours
 TIME-TO-GO MN –time to the next maintenance / service work
 SERVICE – number of completed service calls (2,000 h)

Complete a record for the installation of the compressor assembly and commissioning (see the Annexe in the User manual - Page 30)

Attention:
 The controller display is located inside the switchboard and is only accessible by

opening the switchboard door. The switchboard door may only be opened when the compressor is running by a person trained and competent for such activity.

Under normal circumstances, there is no reason to open the switchboard doors as the compressor is running in automatic mode; the only reason to open the doors is to remedy an alarm or to perform maintenance work.

18. SWITCHING OFF AND SHUTTING DOWN THE COMPRESSOR

Use the main switch, Q10, to switch off the compressor; the switch also functions as a central stop button. This disconnects the compressor from power. Vent the air tank by disconnecting from the central compressed air circuit and opening the outlet valve (Fig. 1) or the air tank drain valve.

Attention:

Power terminals X0 remain energised even when main switch Q10 is in the "O" (off) position.

MAINTENANCE

19. PRODUCT MAINTENANCE

Attention!

The operator shall secure the completion of repeated testing of the equipment at least once every 24 months (EN 62353) or at the intervals defined by applicable national regulations. A record must be completed of the test results (per EN 62353, Annex G) together with the measurement methods.

The equipment has been designed and manufactured to keep maintenance to a minimum. The following work must be performed to preserve the proper and reliable operation of the compressor.



Before starting compressor maintenance work, check to ensure the compressor is disconnected from the appliance to ensure the person using the appliance is not at risk and there is no risk of any other material damages!



Air pumps components (head, cylinder, pressure hose, etc.) are very hot during and shortly after compressor operation – do not touch these components!

The work below may only be performed by trained personnel as follows:



BEFORE BEGINNING ANY OF THE FOLLOWING MAINTENANCE WORK, SWITCH OFF THE MAIN SWITCH ON THE SIDE OF THE SWITCHBOARD TO POSITION "0".



Allow the equipment to cool down before maintenance, service or connecting/disconnecting the compressed air supply!

19.1. Maintenance intervals



These maintenance intervals are valid for products with max. operating pressure of 8 bar!

Attention!

The operator shall secure the completion of repeated testing of the equipment at least once every 24 months (EN 62353) or at the intervals defined by applicable national regulations. A record must be completed of the test results (per EN 62353, Annex G) together with the measurement methods.

Tab. 2

Time interval	Once a day	Once a week	Once a year	Once every 2 years	2000	4000	6000	8000	10000	12000	Chapter	Set of replacement parts	Performed by
Product function check	x										18.2		user
Clean dryer filter grid, inspect the condensate drain and check temperatures on the display		x									See the dryer manual on the CD		user
Clean the dryer condenser, check dryer operation					x	x	x	x	x	x	See the dryer manual on the CD		user
Replace float in separator						x		x		x	18. 7.	025200146-000	user
Equipment inspection					x	x	x	x	x	x	18. 3.		qualified technician
Inspection of electrical connections					x	x	x	x	x	x	18. 4.		qualified technician
Check operation of check valves						x		x		x	See the service manual		qualified technician
Check the function of the pressure switch					x	x	x	x	x	x	See the service manual		qualified technician
Relief valve check					x	x	x	x	x	x	19		qualified technician

Time interval	Once a day	Once a week	Once a year	Once every 2 years	2000	4000	6000	8000	10000	12000	Chapter	Set of replacement parts	Performed by
Replace piston group with bearing							x			x	See the service manual	604031828-X00	qualified technician
Check safety valve operation			x			x		x		x	chapter 18.6.		qualified technician
Check solenoid valve operation						x		x		x	See the service manual		qualified technician
Air pumps intake filter replacement			x		x	x	x	x	x	x	18.5	604031827-X00	qualified technician
If air pumps output decreases, check the condition of the valve plate											See the service manual		qualified technician
Conduct the "Repeated test" per EN 62353				x							18.1		qualified technician
Check pneumatic connections for leaks					x	x	x	x	x	x	18.3		user

19.2. Functionality check

- Check air pumps condition – the air pumps should be operating normally without excessive vibration or noise. Troubleshoot any problem or call in service personnel if trouble is detected
- Check fan operation (visually) – the fans must be running per the description of their function. Troubleshoot any problem or call in service personnel if trouble is detected
- Check to ensure the power cable and connecting pneumatic hoses are undamaged. Replace damaged components or call in service personnel.
- Check the ambient temperature at the display – the ambient temperature must be below the temperature limit (40° C). Cool the space if the temperature is high.
- Check for alarm conditions on the display – troubleshoot and remedy all alarms.

19.3. Leak check compressed air connections and inspect the equipment

Leak testing:

- leak test the compressor's compressed air lines when running - when the compressor is delivering pressure (not during regeneration blowdown).
- Use a leak analyser or soapy water to check all joints and connections for leaks. Tighten or reseal the connection where leaks are found.

Equipment inspection (Fig. 1):

- Check the condition of the compressor air pump for normal operation and noise levels.
- Check the operation of fans.
- Check the condition of filters.
- Check the condition of the air pump itself:
 - contamination in the crankcase and play in the crankshaft
- Replace any parts as needed.

19.4. Inspection of electrical connections



Inspect the product's electrical connections when the mains are disconnected!

Inspection

- Check the mechanical operation of main switch Q10
- Check the power cord, conductors connected to the X1 terminal strip and the main switch to ensure they are undamaged. Inspect to ensure the connection terminals are properly supported to relieve tension.
- Check to ensure all threaded conductor terminals are tight (on motor circuit breakers Q1-3, contactors Q11-13, etc.). Tighten all loose terminals with a screwdriver.
- Visually inspect the connection of individual cables to the terminal strip X1 (spring clips) and the LOGO! control system (screw terminals).
- Inspect all screw terminals for the protective green and yellow PE grounding conductors in the switchboard, the motor section, the cooling unit and the pressure vessel. Tighten any loose terminals
- Inspect connector X5 (dryer and cooler) and the pressure sensor (B1) (on the pressure vessel)

19.5. Air pumps intake filter set replacement
(Fig. 11)



Filters located in the compressor air pumps enclosure cover must be replaced during regular compressor operation.

Inlet filter replacement:

- Pull out the rubber plug by hand (2).
- Remove the used filter (1).
- Insert a new filter and replace the rubber plug.

Pre-filter replacement:

- Pull out the pre-filter by hand (3).
- Replace the element and re-insert.

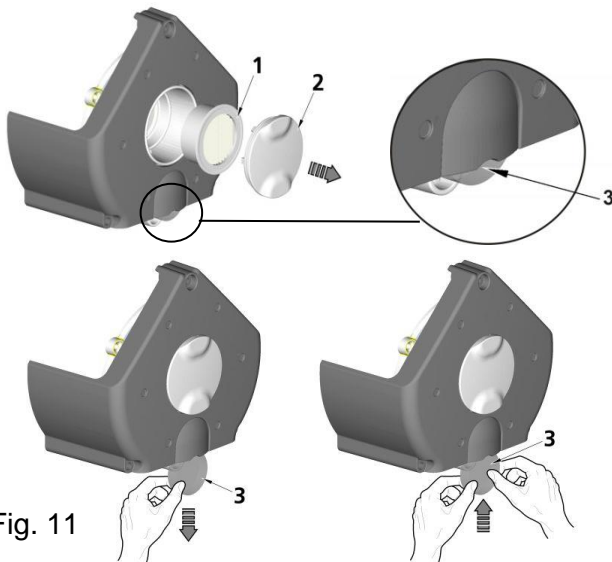

Fig. 11

19.6. Check safety valve operation
(Fig. 12)



Never use the safety valve to release the air pressure in the air tank. It could damage the safety valve. The valve is set to the maximum permitted pressure by the manufacturer. Adjustments are not permitted!



Warning! Compressed air can be dangerous. Wear eye protection, i.e. safety glasses, when venting any air.

- Rotate the screw on the safety valve to the left a number of turns until the valve itself vents.
- Let the safety valve vent for only a few seconds.
- Rotate the screw back to the right (clockwise) to the stop, and the valve must be closed.

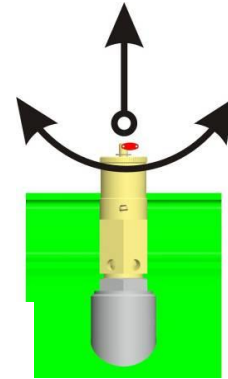

Fig. 12

19.7. Float replacement



BEFORE PROCEEDING, VENT THE AIR TANK TO ZERO PRESSURE AND DISCONNECT THE EQUIPMENT FROM THE ELECTRICAL MAINS.

(Fig. 13)

Replace the float in the water separator at the defined interval

- Check to ensure that all pressure has been vented from the segment with the water separator.
- Disassemble the separator vessel.
- Remove the condensate separator.
- Release the float nut on the bottom of the vessel.
- Remove the worn separator float and replace with a new float.
- Secure the float with the nut on the bottom of the vessel.
- Reinsert the condensate separator as illustrated.
- Reinsert the separator vessel and screw in place.
- The vessel is locked in the position indicated by the symbol.

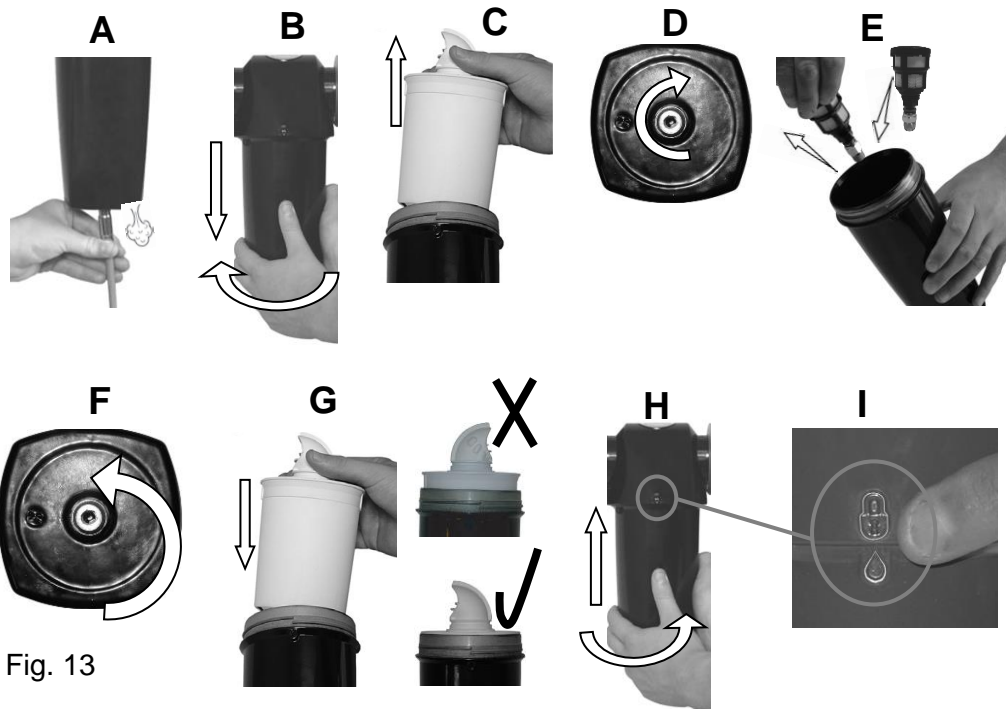



Fig. 13

TROUBLESHOOTING AND REMEDYING PROBLEMS

20. SOLVING COMMON PROBLEMS

 **Caution! Disconnect the equipment from the mains before starting work!**

Troubleshooting may only be performed by trained service personnel!

 **Adjusting the pressure setting of the safety valve is expressly prohibited!**

Pressure relief valve (PRV)

The pressure relief valve automatically begins to vent air from the system if the pressure in the compressed air circuit exceeds its pre-set value. The pressure relief valve (1) closes as the pressure drops. (Fig. 15)

 **Pressure in the compressed air circuit can only increase because of an increase in flow resistance in the compressed air lines or as a result of a dryer malfunction (e.g. solenoid valve malfunction) and therefore repeated opening**

of the relief valve requires a dryer function check and repairs if necessary!

 **Consultation with the manufacturer is required before any adjustment is made to the relief valve!**
The outlet openings on the relief valve may not be blocked and the egress of compressed air through them may not be restricted.

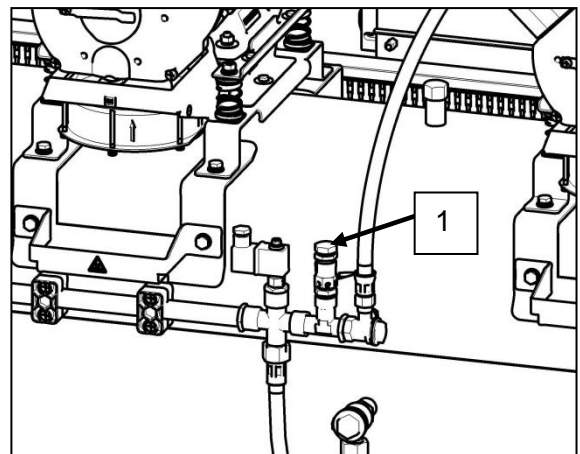

Fig. 14

Tab. 3

MALFUNCTION	POSSIBLE CAUSE	REMEDY
No compressor air pumps starts up	Problem with electrical power source	Main breaker is off
	Power loss	Check mains voltage
		Loose terminal in switchboard - tighten
		Check the primary power connection - replace if damaged
Pressure switch failed	Check terminals and operation of the pressure switch - replace if damaged	
Any of the air pumps does not start up (indicator is on)	Loss of power to motor	Check mains voltage
		Check the function of the contactors, and thermal relays - replace if damaged
		Loose terminals at the motor terminal strip - tighten or replace if damaged or broken
	Motor winding shorted, damaged /open thermal protection/ high ambient temperature	Replace the motor / decrease the ambient temperature
	Seized up piston or other moving component (mechanical damage to a moving part)	Replace damaged parts
Controller malfunction	Check controller operation, check to ensure software is present - replace if damaged or upload the correct program	
RUN/STOP indicator is not green	Loss of connection between controller and expansion module	Check connection – replace if damaged
	Power loss	Check mains voltage
		Loose terminal in switchboard - tighten
		Check the primary power connection - replace if damaged
	Problem with electrical power source	Main breaker is off
Controller or expansion module malfunction	Replace failed controller or expansion module	
Air pumps switch often, even without demand for air	Air leak in compressed air distribution system	Check compressed air distribution system – seal loose joints
	Leaky check valves	Test check vales and clean, or replace if damaged
	Leak through solenoid valves once regeneration is complete	Clean the check valve - replace if damaged
	Leak at pressure sensor and safety valve	Test their function and clean, or replace if damaged
Output of certain air pumps is reduced, extended run cycle	Compressor - air pump leaking	Check connections on the air pump for leaks – tighten leaking connections
	Worn piston rings	Replace worn piston
	Gasket between cylinder head and valve plate damaged	Replace gasket, tighten
	Inlet filter is plugged	Replace old filter with a new filter
One of the air pumps is noisy (knocking, metal noises)	Damaged bearing, motor bearing	Replace damaged bearing
	Damaged piston bearing, piston rod	Replace damaged piston

	Failed (cracked) rubber mount spring	Replace damaged spring with new spring
High ambient temperature causes air pumps to switch off in vertical stacks (overheating)	Lack of ventilation in compressor room	Secure suitable ambient conditions
	Air pumps cooling fans, cooler does not work	Defective fans - replace
		Defective pressure switch - replace
	ED72 dryer	See the dryer manual on the CD
Damp pressure air	Condensing dryer off	Turn on the dryer, drain condensate if there is condensate in the air tank
	Dryer malfunction	Call in service

Once the dryer malfunction is remedied and it is reconnected, the condensate trapped in the air tank must be drained and the air tank must be dried.

The manufacturer reserves the right to make changes to the equipment without notice. Any changes made will not affect the functional properties of the equipment.

21. REPAIR SERVICE

Warranty and post-warranty repairs are provided by the manufacturer or an authorised contractor.

Troubleshooting may only be performed by trained service personnel!

ANNEXES**22. INSTALLATION RECORD**

1. Product: (model) DK50-3x4VR/M		2. Serial number:	
3.1. User's name:			
3.2. Address of installation:			
4. Equipment connected to the compressor:			
5. Installation / Commissioning:		6. Contents of operator training:	
A. Product completeness check **	Y	A. Description of the product and functions**	Y
	N		N
B. Documentation completeness check **	Y	B. Product operation: turning on/off, controls, control procedures, data on the display panel, alarms, operation in alarm conditions**	Y
	N		N
C. Installation/connection to equipment **	Y	C. Product maintenance: maintenance intervals, maintenance procedure, service intervals, operating activities**	Y
	N		N
D. Functional test **	Y	D. Safety measures, warnings – their meaning and compliance **	Y
	N		N
Notes::			
7. Operator instructed on safety measures, operations and maintenance:			
Name :		Signature:	
Name:		Signature:	
Name :		Signature:	
8. Installation and instruction performed by – First name/Last name		Signature:	
Company:		Address:	
Phone:			
Email:		Date:	
9. Distributor:			
Company:		Address:	
Contact person:			
Phone:		Email: :	

** mark with an "X" in points 5 and 6 (Y - yes /N - no). Enter any observations from points 5 and 6 into the "Notes" section



DK50 3X4VR/M

 EKOM spol. s r.o.
Priemyselná 5031/18, 921 01 PIEŠŤANY
Slovak Republic
tel.: +421 33 7967 211, fax: +421 33 7967 223
e-mail: ekom@ekom.sk, www.ekom.sk

NP-DK50 3x4VRM_ED-EN-7_09-2024
112000284-0001

www.ekom.sk